

A RUTHMAN COMPANY

GUSHER PUMPS, INC.
115 INDUSTRIAL DRIVE
WILLIAMSTOWN, KY 41097
PHONE: 859-824-3100
FAX: 859-824-7428
www.gusher.com

MSC4 AND MSC5 MSC4-19A SERIES

MAINTENANCE • INSTALLATION • OPERATIONS

Instruction manual

TABLE OF CONTENTS

PUMP SAFETY TIPS	1
FOREWORD	2
PRECAUTIONS	3
NAMEPLATE INFORMATION	4
RECEIVING & INSPECTION	4
OPERATION & MAINTENANCE.....	5
VERTICAL MULTI-STAGE VERSATILITY	6
MSC4-19A DRAWING	7
MSC4 STANDARD MODELS DRAWING	8
MSC5 STANDARD MODELS 6 STAGES AND ABOVE DRAWING	9
TROUBLESHOOTING	10
DISASSEMBLY PROCEDURE.....	11
FOR ASSEMBLY REVERSE THE ABOVE PROCEDURE.....	11

PUMP SAFETY TIPS

SAFETY APPAREL

- Insulated work gloves when handling hot bearings or using bearing heater
- Heavy work gloves when handling parts that have sharp edges, especially impellers
- Safety glasses (with side shields) to protect eyes, especially in machine shop areas
- Steel-toed shoes to protect feet when handling parts, heavy tools, etc.
- Any other equipment needed to protect against hazardous/toxic fluids

COUPLING GUARDS

- Never operate a pump without coupling guards properly installed

FLANGED CONNECTIONS

- Never force piping to make connection with a pump
- Use only fasteners of proper size and material
- Ensure there are no missing fasteners
- Beware of corroded or loose fasteners

OPERATION

- Do not operate below minimum rated flow, or with suction/discharge valves closed.
- Do not open vent or drain valves, or remove plugs while the system is pressurized

MAINTENANCE SAFETY

- Always lockout power
- Ensure pump is isolated from the system and pressure is relieved before disassembling pump, removing plugs, or disconnecting piping
- Use proper lifting and supporting equipment to prevent serious injury
- Observe proper decontamination procedures
- Know and follow company safety regulations
- Never apply heat to remove impeller

FOREWORD

The design, craftsmanship, and materials used in Gusher pumps provides for optimum performance and long, trouble-free service. As with any mechanical device, proper use and periodic maintenance will enhance the performance and life of your pump. This manual is provided as a guideline for proper installation, operation and maintenance. THIS MANUAL MUST BE READ AND UNDERSTOOD BEFORE INSTALLING AND OPERATING ANY PUMP.

GUSHER PUMPS INC. SHALL NOT BE LIABLE FOR PHYSICAL INJURY, DAMAGE OR DELAYS CAUSED BY A FAILURE TO OBSERVE THE INSTRUCTIONS FOR INSTALLATION, OPERATION, AND MAINTENANCE CONTAINED IN THIS MANUAL.

WARRANTY

Gusher Pumps, Inc. will replace or repair, within one year of shipment from our plant, any pump in our judgment that has failed due to defects in materials or workmanship, provided the pump has been properly installed and maintained and has not been subject to abuse. These pumps must return to Gusher Pumps, Inc. with complete history of service for inspection and warranty consideration. Gusher Pumps, Inc. does not accept the responsibility for transportation to and from our plant. Furthermore, we do not assume any responsibility for consequential damage or loss of production.

WARRANTY IS ONLY VALID WHEN GENUINE GUSHER PARTS ARE USED.

Supervision by an authorized Gusher representative is recommended to ensure proper installation.

Additional manuals can be obtained by contacting your local Gusher representative or by calling 859-824-5001.

PRECAUTIONS

! WARNING !

Personal injury will result if procedures outlined in this manual are not followed.

- NEVER apply heat to remove impeller. It may explode due to trapped liquid.
- NEVER use heat to disassemble pump. Explosion could occur due to trapped liquid.
- NEVER operate pump without coupling guard correctly installed.
- NEVER operate pump beyond the rated conditions to which the pump was sold.
- NEVER start pump without proper prime (sufficient liquid in pump casing).
- NEVER operate pump below recommended minimum flow or when dry.
- ALWAYS lock out power to the motor before performing pump maintenance.
- NEVER operate pump without safety devices installed.
- NEVER operate pump with discharge valve closed.
- NEVER operate pump with suction valve closed.
- DO NOT change conditions of service without approval of an authorized Gusher representative.

NAMEPLATE INFORMATION

On the casing of every Gusher pump is a nameplate that provides information about the pump's hydraulic characteristics. This information will be used when ordering spare or replacement parts for your pump.

Gusher

MODEL

SERIAL HP

VOLTS

AMP. PH.

R.P.M. CY.

REF IMP.

GPM TDH IN FT.

RECEIVING and INSPECTION

Gusher Pumps, Inc. has taken great care in preparing your pump for shipment, however, due to circumstances beyond our control, your shipment may be received damaged. Therefore, we strongly recommend that you take a few minutes to check your pump upon receipt. Check for cracked, bent, severely misaligned (minor misalignments almost always occur during shipment), or even missing parts. If any such damage has occurred, you must report it to the delivering carrier and Gusher Pumps, Inc. immediately.

We also recommend that you check the model number, horsepower, current characteristics, and ft. head of pump received to ensure that you have received the pump you ordered for your specific operating conditions. If you should find some discrepancy, report it to Gusher at once.

If your pump is not going to be installed within six months, several precautions must be taken;

1. Preservative treatment of bearings and machined surfaces is required.
2. Remove packing on pumps with packed stuffing box, the stuffing box and shaft sleeve must be oil lubricated to also protect against moisture.
3. Units equipped with mechanical seals must also be oil lubricated with an oil can through the NPT port while rotating the shaft by hand.
4. Pump suction and discharge ports must be covered to prevent foreign material from getting into the pump and causing damage when pump is started at a later date.
5. Pump must be stored in a dry location.
6. Rotate pump shaft several times every other month.

OPERATION & MAINTENANCE

• OPERATION

Before starting the pump the reservoir should be filled to the minimum level so as to completely submerge the bottom pump impeller housing in the liquid which assures priming of the pump.

Upon initial start up we recommend that you check and maintain the minimum liquid level in your reservoir, it is also advisable to check your piping for leaks at this time. We also recommend that you check and record the pump discharge pressure, line voltage and amperage being drawn by the motor and operating temperature of the bearings. Temperature should be checked with a pyrometer, do not check by touch. Temperatures that are hot to the touch are often well within the maximum operating temperature of 225°F.

If a problem develops check the trouble shooting list on page 10. If you are unable to solve your problem please feel free to contact the factory.

• MAINTENANCE



Normally after proper installation and under normal operating conditions (8 hours daily duty in clean liquid with SG of 1) the pump requires very little attention.

Before shipment all Gusher pumps have been tested and greased at the plant, therefore lubrication is not necessary for approximately six to eight months. Remember, when lubricating ball bearings that too much grease will cause bearings to run hot, so grease bearings sparingly when it is necessary. We recommend the use of Chevron SRI #2 grease.

Because of the vast range of operating conditions it is difficult to recommend one set schedule for periodic maintenance. The more severe the application the more attention the pump will require. When a pump operates in a high temperature application (over 150°F) it is recommended to grease the ball bearings sparingly once a month (approx. 1 gram). In hostile environments where abrasives are present the pump may need to be inspected for wear quarterly. This should include inspection of the impellers, bushings and seals. On hostile duty pumps the lower bushing is constructed of Tungsten Carbide. This material is sensitive to thermal shock. Use caution when rapidly changing the temperature of the liquid. If the temperature change is too rapid bushing failure will occur.

Vertical Multi-Stage Versatility

This maintenance manual only applies to Gusher's standard multistage pumps.

	<p>MODELS MSC4 AND MSC5 End Suction Centrifugal Multi-Stage Available in 3 thru 10 Stages and 1 1/2 thru 25 Horsepower.</p> <p>STANDARD FEATURES:</p> <ol style="list-style-type: none">1. Rugged Grade 30 Cast Iron Construction.2. Built in Mounting Flange.3. Balanced Mechanical Seal.4. Above Mounting Flange Discharge.5. Greased For Life Bearings.6. Standard Motors are 3 Phase, 230/460 Volt, 3450 RPM, and TEFC.7. 3/4" NPT and 1 1/4" NPT Discharge.	
<p>MODEL MSC4</p>		<p>MODEL MSC5</p>

Listed below are some of the options available and due to the various pumps and pump applications this manual may not apply to your specific pump. If you have any questions please consult the factory: 859/824-5001 or FAX: 859/824-3011.

OPTIONS:

Offers Dual Discharges.
One for low Volume and High Pressure,
One for High Volume and Low Pressure,
Both driven by one common motor.

Available up to 36" of immersion with intermediate bushing.

Options available for Standard Models available with Column Tank, with Flanged or Threaded Intake for exterior tank mounting.

Drawings available upon request.



Available in Horizontal Mount Configuration.

MSC4-19A

NOTE: FOR PARTS CONTACT FACTORY WITH SERIAL NUMBER

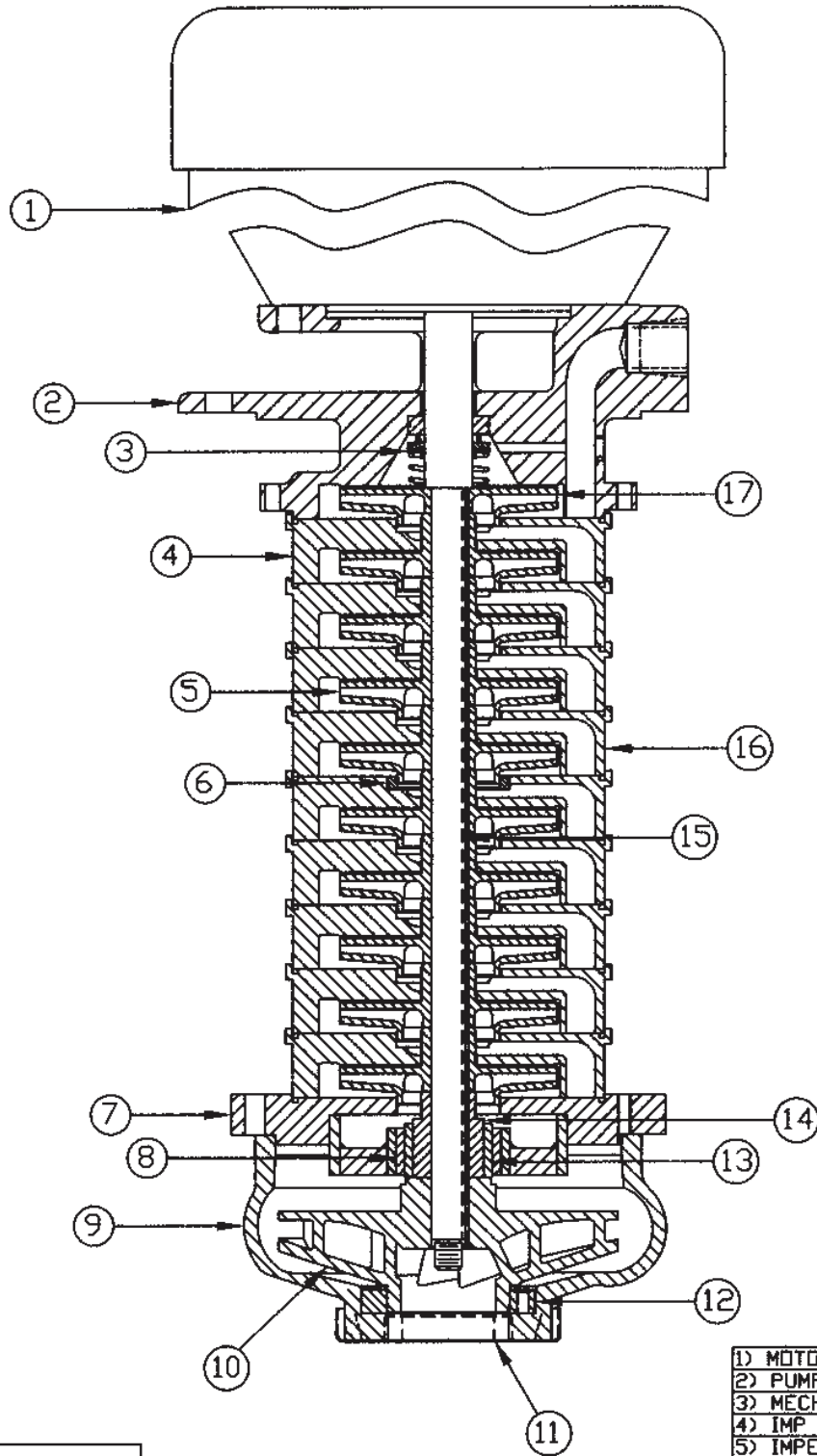

1) MOTOR	10) IMPELLER
2) PUMP BODY	11) STRAINER
3) MECH SEAL	12) WEAR RING
4) IMP HSG	13) TC SLEEVE
5) IMPELLER	14) SLEEVE
6) CARBON BUSH	15) SHAFT
7) ADAPTER	16) IMP HSG
8) TC BUSHING	17) IMPELLER
9) IMP HSG	

GUSHER PUMPS

DIVISION OF RUTHMAN PUMP AND ENGINEERING, INC.
RUTHMAN DRIVE-DRY RIDGE, KENTUCKY 41035

AK 080819-204

MSC4 STANDARD MODELS

NOTE: FOR PARTS CONTACT FACTORY WITH SERIAL NUMBER

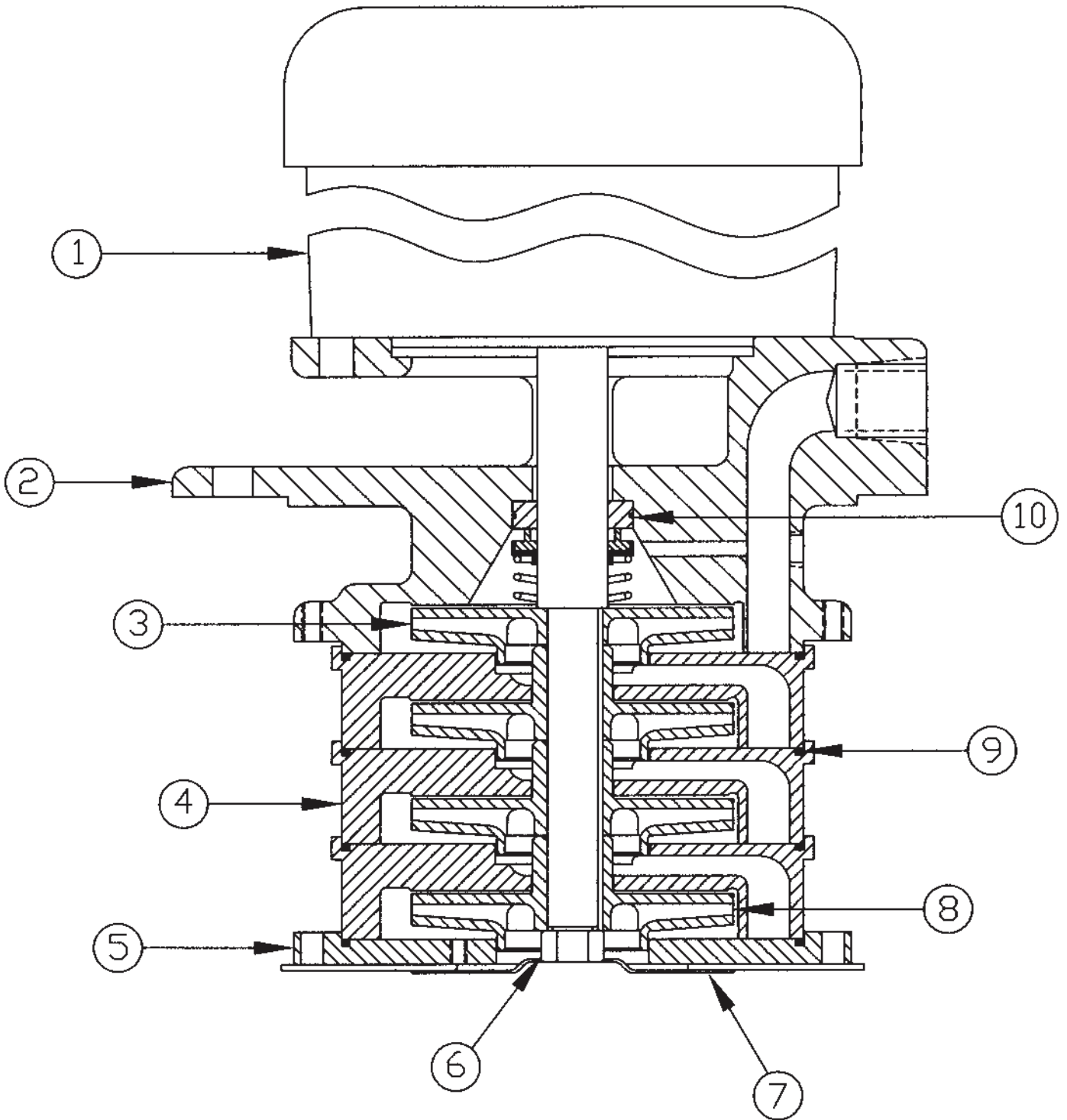

GUSHER PUMPS
 DIVISION OF RUTHMAN PUMP AND ENGINEERING, INC.
 RUTHMAN DRIVE-DRY RIDGE, KENTUCKY 41035
 AK 080819-203

1) MOTOR	6) RET NUT
2) PUMP BODY	7) STRAINER
3) IMPELLER	8) IMPELLER
4) IMP HSG	9) O-RING
5) INT FLG	10) MECH SEAL

MSC5 STANDARD MODELS 6 STAGES AND ABOVE

- *EXTENDED 6"
 - *TC BUSHING/SLEEVE
 - *VITON/SC/SC/TYPE 8 SEAL
 - *BUILT WITH 2 STAGES BELOW EXTENSION
- NOTE: FOR PARTS CONTACT FACTORY WITH SERIAL NUMBER

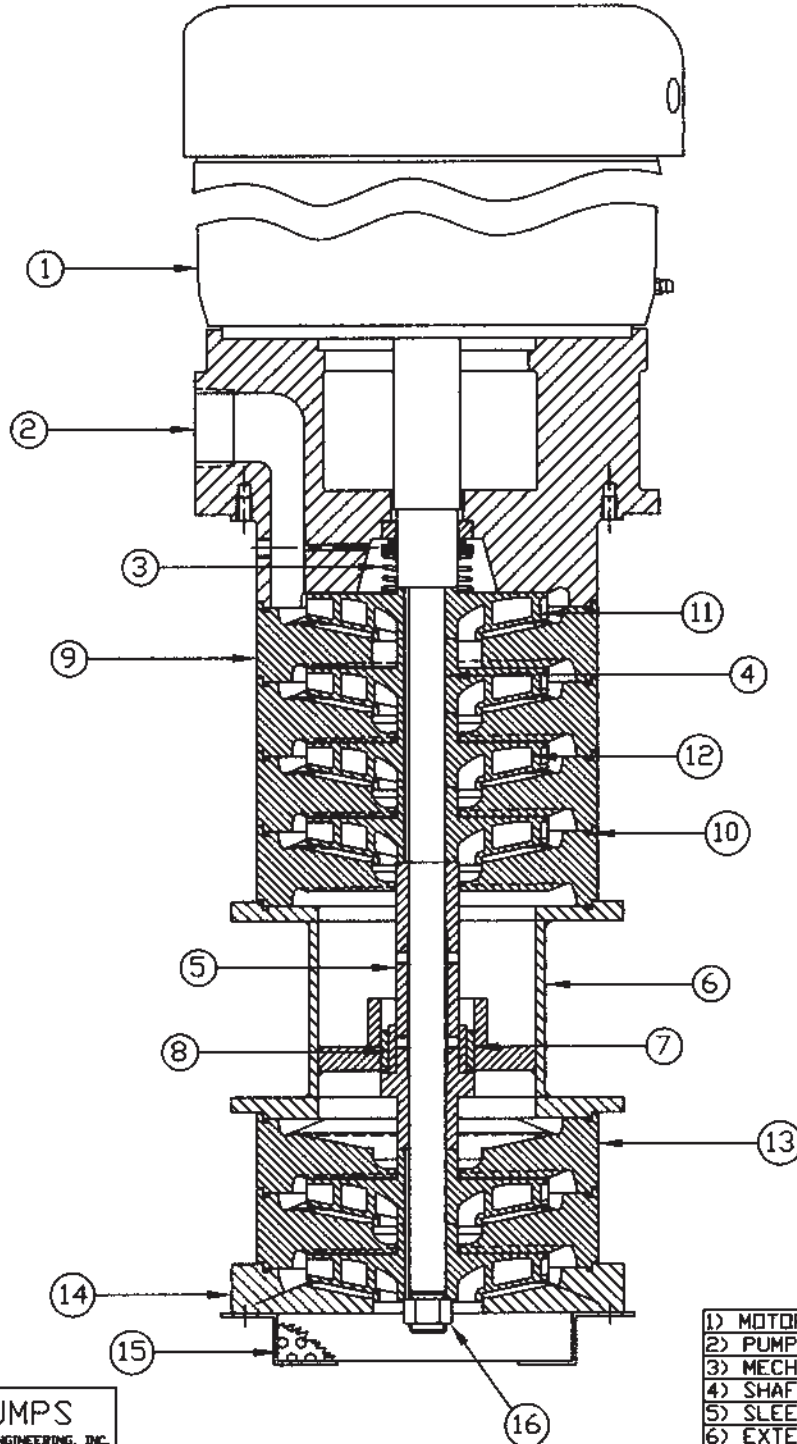

1) MOTOR	9) IMP HSG (1)
2) PUMP BODY	10) O-RING
3) MECH SEAL	11) IMPELLER (1)
4) SHAFT	12) IMPELLER (5)
5) SLEEVE	13) IMP HSG (5)
6) EXTENSION	14) INTAKE FLANGE
7) TC BUSHING	15) STRAINER
8) TC SLEEVE	16) RET NUT

GUSHER PUMPS
 DIVISION OF RUTHMAN PUMP AND ENGINEERING, INC.
 RUTHMAN DRIVE-DRY RIDGE, KENTUCKY 41035
 AK 080819-201

TROUBLESHOOTING

No liquid delivered

- Pump not primed
- Speed too low*
- Discharge head too high
- Suction line or suction strainer is clogged
- Impeller completely clogged
- Wrong direction of rotation
- Too much clearance between impeller and intake flange

Not enough water delivered

- Air leaks in suction or stuffing boxes
- Speed too low*
- Discharge head higher than anticipated
- Too much clearance between impeller and intake flange
- Impeller partially clogged
- Not enough suction head for hot water
- Mechanical defects:
 - Wear ring is worn
 - Impeller damaged
- Impeller diameter is too small
- Foot valve is too small
- Foot valve or suction opening not submerged deep enough

Vibration

- Bent shaft
- Pipe strain
- Impeller clogged
- Coupling alignment off

Not enough pressure

- Speed too low*
- Air in water
- Mechanical defects:
 - Wear ring is worn
 - Impeller damaged
- Impeller diameter too small

Pump works for a while then loses suction

- Leaky suction line
- Water seal plugged
- Impeller clogged
 - Air or gasses in liquid

Pump takes too much power

- Speed too high*
- Head lower than rating, pumps too much water
- Specific gravity or viscosity too high
- Mechanical defects:
 - Shaft bent
 - Power frame in bind
 - Wear ring is worn
- Impeller diameter too large
- Pump delivering too many gallons

* When directly connected to electric motors, check for full voltage across all electrical leads

DISASSEMBLY PROCEDURE

1. Turn the pump over to where the intake flange is up.
2. CAUTION! Before proceeding, be sure to mark the impeller housing on the outside so that you can put them back on in exactly the same position that you take them off and also number them so that you can put them back on in exactly the same order that they came off.
3. Remove the intake flange retaining bolts and remove the intake flange.
4. Before continuing, you need to remember to number the impellers so that you can put them back on in exactly the same order that you take them off of the shaft.
5. Remove the impeller retaining nut and remove the impeller. If the impeller is worn, replace it.
6. Remove the impeller housing. If the housing is worn, replace it.
7. Continue removing the impellers and the impeller housings remembering to mark impeller housings for position and the order that they are in; also remember to mark the impellers as far as order until you get to the final impeller.
8. When you get to the last impeller, extreme care should be taken in removing the last impeller because the mechanical seal is directly behind this impeller.

FOR ASSEMBLY REVERSE THE ABOVE PROCEDURE

In order to insure proper reassembly of your pump, be sure to do the following things:

1. Check the seal. If it is worn, replace it.
2. When you press the seat of the seal on the impeller use something that is non-metallic so that it won't damage the seal. Also, lubricate the impeller before pressing the seal onto the impeller hub.
3. When installing the impellers and the impeller housings, they must go back onto the shaft exactly the same way that they were removed.
4. Once you have reassembled the pump and have put the external fan back onto the shaft, rotate the pump shaft by hand to make sure that the pump turns freely and is not in a bind.

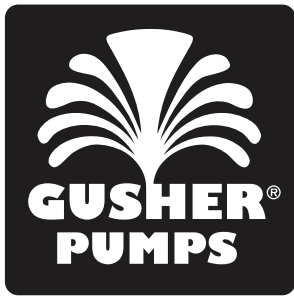

A RUTHMAN COMPANY

**Gusher Pumps is a Division of
Ruthman Companies
Corporate Headquarters**

1212 Steng Street
Cincinnati, OH 45233
Phone: 513-559-1901
Fax: 513-559-0035
Web: www.ruthmancompanies.com

**Gusher Pumps of Dry Ridge
22 Ruthman Drive**

Dry Ridge, KY 41035
Phone: 859-824-5001
Fax: 859-824-3011
Web: www.gusher.com

**Gusher Pumps of Williamstown
115 Industrial Drive**

Williamstown, KY 41097
Phone: 859-824-3100
Fax: 859-824-7248
Web: www.gusher.com

**Gusher Pumps of Cincinnati
1212 Steng Street**

Cincinnati, OH 45233
Phone: 513-559-1901
Fax: 513-559-0035
Web: www.gusher.com

Gusher Pumps of California

8226 Salt Lake Avenue
Cudahy, CA 90201
Phone: 323-773-0847
Fax: 323-773-0958
Email: www.gusherca@aol.com

Gusher Pumps of New Castle

403 North Ninth Street
New Castle, IN 47362
Phone: 765-529-5624
Fax: 765-521-0008
Email: www.gusherpump@insightbb.com

BSM Pump Corp.

180 Frenchtown Road
North Kingstown, RI 02852
Phone: 401-471-6350
Fax: 401-471-6370
Web: www.bsmpump.com

Nagle Pumps

1249 Center Avenue
Chicago Heights, IL 60411
Phone: 708-754-2940
Fax: 708-754-2944
Web: www.naglepumps.com



Ruthman... Another Word for Innovation



It began in 1913, servicing mechanical components of the steamboats on the Ohio River. The company founder, Alois Ruthman, was a man of vision and saw part of the future of the company was in the development of a reliable industrial pump.

In 1924, with the conception of the first vertical ball bearing seal-less centrifugal pump, Ruthman Pump and Engineering furthered the design on a unit with a one piece motor driven shaft. The pump was called "Gusher", giving birth to the trade name Gusher Pumps, and the coining of the term "coolant pump".

Wanting to carry on the tradition of quality and reliability started by his father, Thomas R. Ruthman joined the company in 1949. In the early 1990's Thomas R. Ruthman's son, Thomas G. Ruthman joined the company, continuing this same tradition. Maintaining the reputation of Gusher Pumps by innovation and customer service, the company has grown to service companies worldwide.

Wagner Processing - Bay Area

23510 Bernhardt Street
Hayward, CA 94545
Phone: 510-786-3929
Fax: 510-786-3722
Web: www.wagnerprocess.com

Wagner Processing - Central Valley

3675 N. Wilcox Street #C
Stockton, CA 95215
Phone: 209-931-0100
Fax: 209-931-7910
Web: www.wagnerprocess.com

Great Lakes Pump & Supply Co.

1075 Naughton
Troy, MI 48083
Phone: 248-528-9100
Fax: 248-528-9015
Web: www.greatlakespump.com

Process Systems, Inc.

Michigan, Main Headquarters
23633 Pinewood
Warren, MI 48091
Phone: 586-757-5711
Fax: 586-758-6996
Web: www.INFOatpsi4pumps.com
Indiana
485 N State Route 3431 South
Mellott, IN 47958
Phone: 765-295-2206
Fax: 765-295-2243
Web: www.process-systems-inc.com

Worldwide:

Ruthmann Pumpen

Northberger Strabe 60
Eschweiler Germany D-52249
Phone: +49 (0) 2403 5595 0
Fax: +49 (0) 2403 5595 20
Web: www.ruthmannpumpen.de
Birmingham Pump
Unit 7 Network Park
Duddeston Mill Road
Saltley, Birmingham England B81AU
Phone: +44 (0) 121 503 3000
Fax: +44 (0) 121 503 3002
Web: www.birminghampumps.co.uk

Guan Shen Industrial Pumps

(Shanghai) Company
广申工业泵(上海)有限公司
Gusher Pumps (Shanghai) Co., Ltd.
Building D, Room 416
No. 188 East Jiangwan Road
Shanghai, 200081
P.R. CHINA
上海市东江湾路 188 号 D 栋 416 室
Phone: 86-21-33872056
Phone: 86-21-33872058
Fax: 86-21-33872057

电话: 86-21-33872056
86-21-33872058
传真: 86-21-33872057