

Gusher Model 9065 182MM Industrial Coolant Pump

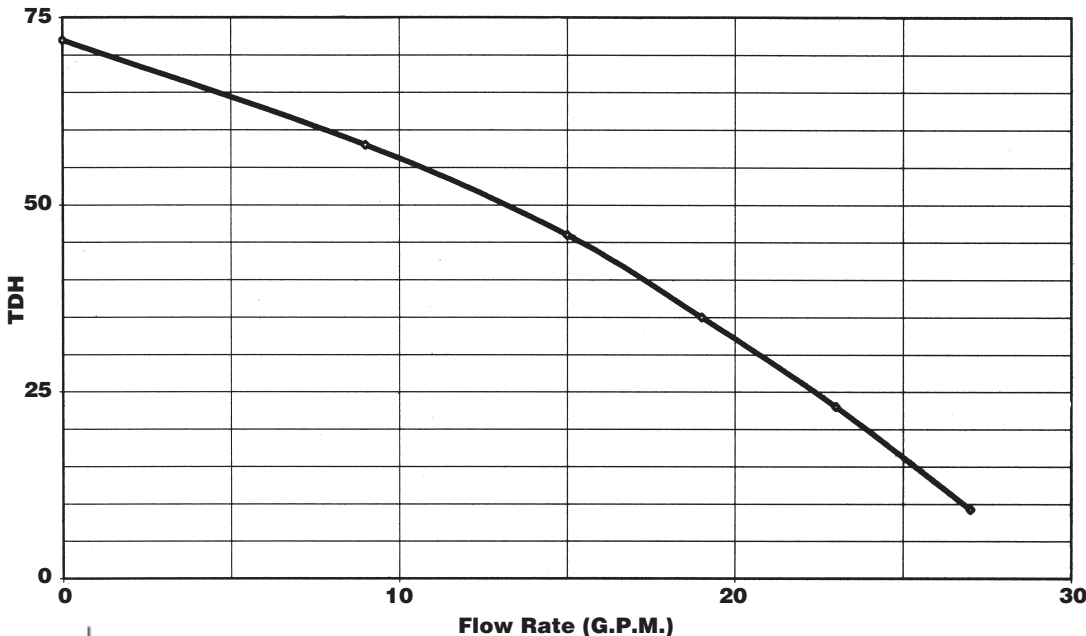

- Above mounting plate discharge
- Offered in both single and three phase
- One piece, integral shaft
- High flow and volume for today's modern machine tool
- Mounting bracket not required, incorporated in design
- Power cord available
- Very cost effective
- Light weight aluminum 356-T6 construction
- Available in 1ph, 3ph and 50 or 60 Hertz @ .75hp
- Rated 5 GPM @ 65 ft. and 25 GPM @ 15 ft. @ 60 Hertz
- 19 l/m @ 20m and 95 l/m @ 4.5m @ 60 Hertz

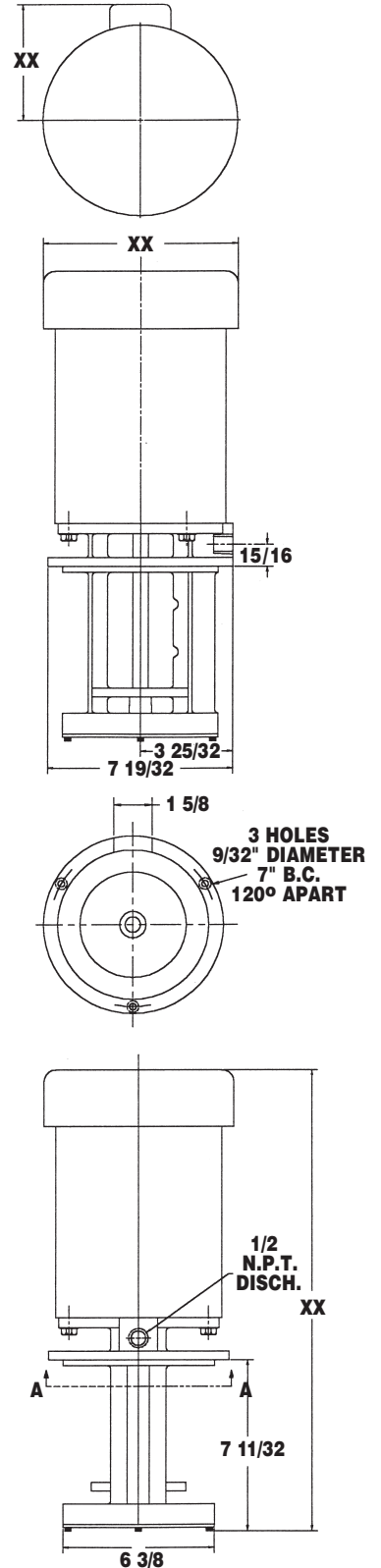



A RUTHMAN COMPANY

Gusher Pumps is a Division of Ruthman Companies

Corporate Headquarters

1212 Steng Street
Cincinnati, OH 45233

Phone: 513-559-1901

Fax: 513-559-0035

Web: www.ruthmancompanies.com

Gusher Pumps of Dry Ridge

22 Ruthman Drive
Dry Ridge, KY 41035

Phone: 859-824-5001

Fax: 859-824-3011

Web: www.gusher.com

Gusher Pumps of Williamstown

115 Industrial Drive
Williamstown, KY 41097

Phone: 859-824-3100

Fax: 859-824-7248

Web: www.gusher.com

Gusher Pumps of Cincinnati

1212 Steng Street
Cincinnati, OH 45233

Phone: 513-559-1901

Fax: 513-559-0035

Web: www.gusher.com

Gusher Pumps of California

8226 Salt Lake Avenue
Cudahy, CA 90201

Phone: 323-773-0847

Fax: 323-773-0958

Email: www.gusherca@aol.com

Gusher Pumps of New Castle

403 North Ninth Street
New Castle, IN 47362

Phone: 765-529-5624

Fax: 765-521-0008

Email: www.gusherpump@insightbb.com

BSM Pump Corp.

180 Frenchtown Road
North Kingstown, RI 02852

Phone: 401-471-6350

Fax: 401-471-6370

Web: www.bsmpump.com

Nagle Pumps

1249 Center Avenue
Chicago Heights, IL 60411

Phone: 708-754-2940

Fax: 708-754-2944

Web: www.naglepumps.com

Ruthman... Another Word for Innovation



reliable industrial pump.

In 1924, with the conception of the first vertical ball bearing sealless centrifugal pump, Ruthman Pump and Engineering furthered the design on a unit with a one piece motor driven shaft. The pump was called "Gusher", giving birth to the trade name Gusher Pumps, and the coining of the term "coolant pump".

Wanting to carry on the tradition of quality and reliability started by his father, Thomas R. Ruthman joined the company in 1949. In the early 1990's Thomas R. Ruthman's son, Thomas G. Ruthman joined the company, continuing this same tradition. Maintaining the reputation of Gusher Pumps by innovation and customer service, the company has grown to service companies worldwide.

It began in 1913, servicing mechanical components of the steamboats on the Ohio River. The company founder, Alois Ruthman, was a man of vision and saw part of the future of the company was in the development of a

Wagner Processing – Bay Area

23510 Bernhardt Street
Hayward, CA 94545

Phone: 510-786-3929

Fax: 510-786-3722

Web: www.wagnerprocess.com

Wagner Processing – Central Valley

3675 N. Wilcox Street #C
Stockton, CA 95215

Phone: 209-931-0100

Fax: 209-931-7910

Web: www.wagnerprocess.com

Great Lakes Pump & Supply Co.

1075 Naughton
Troy, MI 48083

Phone: 248-528-9100

Fax: 248-528-9015

Web: www.greatlakespump.com

Worldwide:

Ruthmann Pumpen

Northberger Strabe 60
Eschweiler Germany D-52249

Phone: +49 (0) 2403 5595 0

Fax: +49 (0) 2403 5595 20

Web: www.ruthmannpumpen.de

Birmingham Pump

Unit 7 Network Park
Duddeston Mill Road
Saltley, Birmingham England B81AU

Phone: +44 (0) 121 503 3000

Fax: +44 (0) 121 503 3002

Web: www.birminghampumps.co.uk

Guan Shen Industrial Pumps (Shanghai) Company

广申工业泵(上海)有限公司

Gusher Pumps (Shanghai) Co., Ltd.

Building D, Room 416
No. 188 East Jiagwan Road
Shanghai, 200081
P.R. CHINA

上海市东江湾路 188 号 D 栋 416 室

Phone: 86-21-33872056

Phone: 86-21-33872058

Fax: 86-21-33872057

电话: 86-21-33872056

86-21-33872058

传真: 86-21-33872057

