



A RUTHMAN COMPANY

Installation, Operation, and Maintenance Manual

7071 Series
ANSI Standard
and Vortex Process
Industry Pumps

GUSHER PUMPS, INC.
115 Industrial Drive
Williamstown, KY 41097
PHONE: 859.824.5001
FAX: 859.824.7428
www.Gusher.com

PUMP SAFETY TIPS

SAFETY APPAREL

- Insulated work gloves when handling hot bearings or using bearing heater
- Heavy work gloves when handling parts that have sharp edges, especially impellers
- Safety glasses (with side shields) to protect eyes, especially in machine shop areas
- Steel-toed shoes to protect feet when handling parts, heavy tools, etc.
- Any other equipment needed to protect against fluids

COUPLING GUARDS

- Never operate a pump without coupling guards properly installed

FLANGED CONNECTIONS

- Never force piping to make connection with a pump
- Use only fasteners of proper size and material
- Ensure there are no missing fasteners
- Beware of corroded or loose fasteners

OPERATION

- Do not operate below minimum rated flow, or with suction/discharge valves closed
- Do not open vent or drain valves, or remove plugs while the system is pressurized

MAINTENANCE SAFETY

- Always lockout power
- Ensure pump is isolated from the system and pressure is relieved before disassembling pump, removing plugs, or disconnecting piping
- Use proper lifting and supporting equipment to prevent serious injury
- Observe proper decontamination procedures
- Know and follow company safety regulations
- Never apply heat to remove impeller

FOREWORD

The design, craftsmanship, and materials used in Gusher pumps provides for optimum performance and long, trouble-free service. As with any mechanical device, proper use and periodic maintenance will enhance the performance and life of your pump. This manual is provided as a guideline for proper installation, operation and maintenance. THIS MANUAL MUST BE READ AND UNDERSTOOD BEFORE INSTALLING AND OPERATING ANY 7071 SERIES ANSI STANDARD DIMENSION PUMP.

GUSHER PUMPS INC. SHALL NOT BE LIABLE FOR PHYSICAL INJURY, DAMAGE OR DELAYS CAUSED BY A FAILURE TO OBSERVE THE INSTRUCTIONS FOR INSTALLATION, OPERATION, AND MAINTENANCE CONTAINED IN THIS MANUAL.

WARRANTY

Gusher Pumps, Inc. will replace or repair, within one year of shipment from our plant, any pump in our judgment that has failed due to defects in materials or workmanship, provided the pump has been properly installed and maintained and has not been subject to abuse. These pumps must return to Gusher Pumps, Inc. with complete history of service for inspection and warranty consideration. Gusher Pumps, Inc. does not accept the responsibility for transportation to and from our plant. Furthermore, we do not assume any responsibility for consequential damage or loss of production.

WARRANTY IS ONLY VALID WHEN GENUINE GUSHER PARTS ARE USED.

Supervision by an authorized Gusher representative is recommended to ensure proper installation.

Additional manuals can be obtained by contacting your local Gusher representative or by calling (859) 824-5001.

TABLE OF CONTENTS

GENERAL INFORMATION.....	4
INSTALLATION	7
OPERATION	14
MAINTENANCE.....	17
DISASSEMBLY	22
REASSEMBLY	26
APPENDIX	32

GENERAL INFORMATION

PRECAUTIONS	5
PUMP DESCRIPTION	5
NAMEPLATE INFORMATION	6
RECEIVING and INSPECTION	7
STORAGE	7
HANDLING.....	7

PRECAUTIONS

! WARNING !

Personal injury will result if procedures outlined in this manual are not followed.

- NEVER apply heat to remove impeller. It may explode due to trapped liquid.
- NEVER use heat to disassemble pump. Explosion could occur due to trapped liquid.
- NEVER operate pump without coupling guard correctly installed.
- NEVER operate pump beyond the rated conditions to which the pump was sold.
- NEVER start pump without proper prime (sufficient liquid in pump casing).
- NEVER operate pump below recommended minimum flow or when dry.
- ALWAYS lock out power to the motor before performing pump maintenance.
- NEVER operate pump without safety devices installed.
- NEVER operate pump with discharge valve closed.
- NEVER operate pump with suction valve closed.
- DO NOT change conditions of service without approval of an authorized Gusher representative.

PUMP DESCRIPTION

The 7071 Series is a horizontal, open impeller centrifugal pump that meets dimension specifications of ANSI B-73.1.

The series consists of 5 power ends and 33 pump sizes as follows:

S Frame	5 pump sizes
M Frame	18 pump sizes
MXL Frame	7 pump sizes
XL Frame	3 pump sizes

Heavy Duty Casings - 300 psi wall thickness increases life under corrosive and erosive conditions. All sizes are self-venting with centerline discharge. Drain plug offered as an option.

Heavy Duty Shaft - Minimum deflection increases life for less maintenance.

Renewable Shaft Sleeve - Hook type sleeve eases maintenance (easily removed) and is relieved to allow for changes in temperature.

Power Frame - Heavy duty Power Frame is sealed against contaminants to ensure long bearing life. Water cooled for high temperature applications.

Oil Lubrication - Oil lubrication is standard. The oil level is maintained by a sight gauge and power frame is vented. Oil may also be water cooled for high temperature application all power frames are jacketed as standard.

Heavy Duty Thrust Bearing - Double row thrust bearing minimizes shaft end play for more effective stuffing box sealing, longer mechanical seal life, and withstands greater axial and radial thrust loads.

External Impeller Adjustment - Like new clearance can be maintained with simple external adjustment in just minutes to maintain original high efficiencies.

Rabbeted Fits - Accurately machined rabbets ensure positive alignment, longer seal life, easy replacement of spare rotating element when maintenance is required.

Contained Casing Gasket - Protects against blow out.

Positive Sealing at Impeller - Teflon O-Ring protects shaft from liquid being pumped.



Fully Open Impeller - is designed with back pump-out vane to minimize axial thrust, and designed to handle solids and stringy material.

Jacketed Stuffing Box - Is offered for high temperature applications to increase seal or packing life in temperatures up to 500°F (260°C).

Direction of Rotation -The impeller must turn counter-clockwise when viewed through the suction opening of the pump.

NAMEPLATE INFORMATION

On every Gusher pump is a nameplate that provides information about the pump's hydraulic characteristics. This information will be used when ordering spare or replacement parts for your pump.

Gusher	<small>LOW VOLTAGE</small> 	<small>HIGH VOLTAGE</small> 	<small>TO REV. ROT INTERCHANGE #5 L #8</small>
MODEL	<input style="width: 100%;" type="text"/>		
SERIAL	<input style="width: 60%;" type="text"/>	HP	<input style="width: 20%;" type="text"/>
VOLTS	<input style="width: 100%;" type="text"/>		
AMP.	<input style="width: 60%;" type="text"/>	PH.	<input style="width: 20%; text-align: center; border: 1px solid black;" type="text" value="3"/>
R.P.M.	<input style="width: 60%;" type="text"/>	CY.	<input style="width: 20%;" type="text"/>
REF	<input style="width: 60%;" type="text"/>	IMP.	<input style="width: 20%;" type="text"/>
GPM	<input style="width: 60%;" type="text"/>	TDH IN FT.	<input style="width: 20%;" type="text"/>

RECEIVING and INSPECTION

Gusher Pumps, Inc. has taken great care in preparing your pump for shipment, however, due to circumstances beyond our control, your shipment may be received damaged. Therefore, we strongly recommend that you take a few minutes to check your pump upon receipt. Check for cracked, bent, severely misaligned (minor misalignments almost always occur during shipment), or even missing parts. If any such damage has occurred, you must report it to the delivering carrier and Gusher Pumps, Inc. immediately.

We also recommend that you check the model number, horsepower, current characteristics, g.p.m., and ft. head of pump received to ensure that you have received the pump you ordered for your specific operating conditions. If you should find some discrepancy, report it to Gusher at once.

Storage

If your pump is not going to be installed within six months, several precautions must be taken;

1. Preservative treatment of bearings and machined surfaces is required.
2. Remove packing on pumps with packed stuffing box, the stuffing box and shaft sleeve must be oil lubricated to also protect against moisture.
3. Units equipped with mechanical seals must also be oil lubricated with an oil can through the NPT port while rotating the shaft by hand.

4. Pump suction and discharge ports must be covered to prevent foreign material from getting into the pump and causing damage when pump is started at a later date.
5. Pump must be stored in a dry location.
6. Rotate pump shaft several times every other month.

Handling

! WARNING !

Pump and components are heavy. Serious physical injury or damage to equipment could occur from failure to properly lift and support pump. Steel-toed shoes must be worn at all times.

Use care when moving pumps. Lifting equipment must be able to sufficiently support the entire pump. Refer to Figs. 2a, b, c for proper lifting techniques.

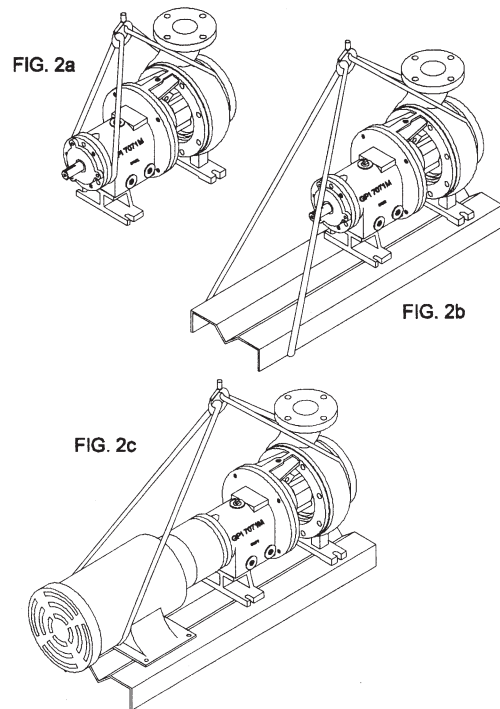

INSTALLATION

PREPARATION	8
LOCAL/FOUNDATION.....	8
LEVEL BASEPLATE	9-10
COUPLING ALIGNMENT PROCEDURE	10
ALIGNMENT CHECKS.....	10
ALIGNMENT CRITERIA.....	11
ANGULAR ALIGNMENT.....	11
PARALLEL ALIGNMENT	11
ALIGNMENT TROUBLESHOOTING.....	11
GROUT BASEPLATE	12
PIPING.....	12
SUCTION PIPING	13
DISCHARGE PIPING.....	14
FINAL PIPING CHECK.....	14

PREPARATION

When preparing your pump for installation, the discharge and suction ports must be clean and free of anything that might prohibit a tight connection. This is especially important on the suction, air leaks can cause a pump to operate poorly or to lose prime completely.

If your pump has just been taken out of storage all of the grease or preservative must be removed from the ball bearing housing. The ball bearing housing must then be thoroughly cleaned with kerosene or carbon tetrachloride and relubricated. On packed pumps, it will be necessary to clean the shaft sleeve and stuffing box with kerosene or carbon tetrachloride and then repack.

LOCATION/FOUNDATION

Whenever possible locate pump far enough below the minimum liquid level in the reservoir so there will be a positive head on the suction at all times. Where this is not possible, the pump should be located as near the source of supply

as possible. Allow ample room for inspection and maintenance. Baseplate mounted pumps are usually grouted on a concrete foundation that has been poured on a solid footing. The foundation should be of heavy construction to

reduce vibration and must be rigid enough to resist the torque it may be subjected to. The foundation should be 2" to 6" larger than the base, depending on the size of the base. A

space of approximately 2" should be left between the foundation and the bottom of the base for grouting. Use a pipe sleeved bolt (Fig. 3) to within 1/2" of the base for a foundation bolt.

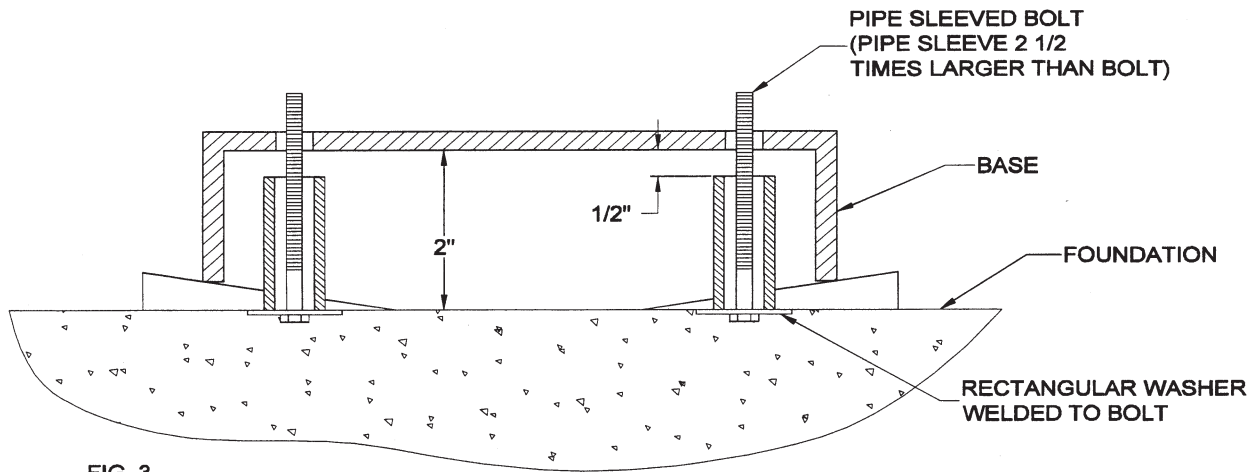

FIG. 3

LEVEL BASEPLATE

Fab. Steel

It should be noted at this time that **SPECIAL CARE** must be taken when leveling your pump for alignment, it is of the utmost importance. Once the pump is set the only means of adjusting is by shimming.

1. Place 12 wedges on the foundation, one wedge on each side of every mounting bolt. Place wedges so that baseplate is 3/4" above foundation to allow for adequate grouting (Fig. 4).
2. Carefully lower the baseplate onto mounting bolts.

3. Level baseplate to within 1/8" over the length and to within .088 in. over the width by adjusting the wedges.
4. Hand tighten bolts.

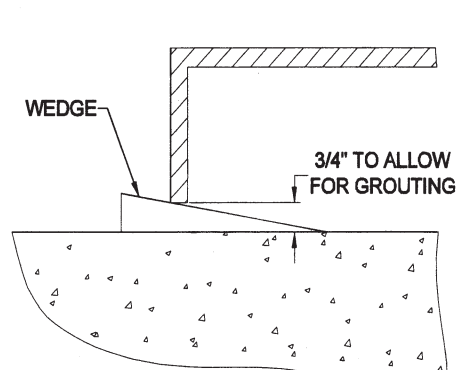

NOTE:
WEDGE SHOULD
BE 2" TAPER PER FT.

1. Coat all jack screws with an anti-seizing compound to allow for easy removal after the grout has cured.
2. Cut 6 round plates from barstock to set the jack screws on. Chamfering the edges of the plate is recommended to reduce stress concentrations.
3. Set the baseplate on the foundation, then raise it 3/4" to 1 1/2" using the four corner jack screws. At this time, the two center jack screws should not be touching the foundation.
4. Place one machinist level lengthwise on a single motor pad, and another across the ends of both motor pads. (It is important that the surface being leveled is free of all contaminants, such as dust, to ensure that your reading is accurate.)
5. Adjust the four jack screws in order to level the motor pads to zero in both directions.
6. Turn down the center jack screws until they are resting on their metal plates.
7. Move the two levels to the pump pads. Place one level lengthwise on a single pad, and the other across the middle of both pump pads.
8. Adjust the jack screws to level the pump pads in both directions.
9. Install the anchor bolts until they are hand tight.
10. Recheck the motor pads for level measurements.
11. Continue adjusting the jackscrews and anchor bolts until all level measurements are within the requirement of 0.002 on in./ft.

COUPLING ALIGNMENT PROCEDURE

! WARNING !

Before starting any alignment procedure, ensure that the motor power is locked out. Failure to do this will result in serious physical injury.

For trouble-free operation of this unit, proper alignment must be attained. Proper alignment is the responsibility of the installer and user of this pump.

Alignment Checks

Initial Alignment (Cold Alignment)

- Before grouting baseplate to make certain alignment can be obtained
- After grouting baseplate to make sure no changes have occurred.
- After connecting piping to ensure that alignment hasn't been altered by pipe strain. If alignment has changed alter piping to remove strain.

Final Alignment (Hot Alignment)

- After first run to obtain correct alignment when equipment is at operating temperature.

Alignment Criteria

Good alignment is achieved when the differences between the readings is .010 or less when the pump is at operating temperature. However, during the installation phase it is necessary to set the parallel alignment in the vertical direction to a different criteria. This is due to the differences in the expansion rates of the pump and the motor. The recommended cold settings for electric motor driven pumps is shown in Table 1.

TABLE 1 COLD SETTING OF PARALLEL VERTICAL ALIGNMENT	
Pumpage Temperature	Set Driver Shaft
50°F (10°C)	.002 in. Low
150°F (65°C)	.001 in. High
250°F (120°C)	.005 in. High
350°F (175°C)	.009 in. High
450°F (218°C)	.013 in. High
550°F (228°C)	.017 in. High
650°F (343°C)	.021 in. High
700°F (371°C)	.023 in. High

Angular Alignment

Check angular alignment with a micrometer or caliper. Measure from the outside of one flange to the outside of the other flange at intervals around the periphery of the coupling, DO NOT rotate the coupling. The difference between the maximum and the minimum must not exceed .010”.

Parallel Alignment

Check parallel alignment by placing a straight edge across the two coupling flanges and measure the offset at various points around the periphery of the coupling. DO NOT rotate the coupling. If offset exceeds .010” realign the coupling.

If a correction is necessary to either the angular or parallel alignment, remember to recheck the other for proper alignment.

ALIGNMENT TROUBLESHOOTING

Problem	Probable Cause	Solution
Cannot obtain horizontal alignment, angular or parallel	The bolts holding the driver feet are bound.	Loosen pump hold down bolts and slide pump and driver until horizontal alignment is achieved.
	Baseplate not leveled properly, probably twisted.	Determine which corner(s) of baseplate are high or low and adjust properly, then realign.
Cannot obtain vertical alignment, angular or parallel	Baseplate not leveled properly, probably bowed.	Determine if center of baseplate should be raised or lowered, and adjust properly.

GROUT BASEPLATE

1. Clean the areas on the baseplate that will contact grout. Do not use oil-based cleaners because the grout will not bond to it.
2. Build a form around the base as illustrated in Fig. 5. Then thoroughly wet the foundation.
3. Pour grout into form being sure that it flows under the base. Fill to within 3/4" to 1" from the bottom of the base.
4. Allow grout to set for 48 hours.
5. Recheck coupling alignment, make any adjustments that may be necessary and tighten foundation bolts securely.

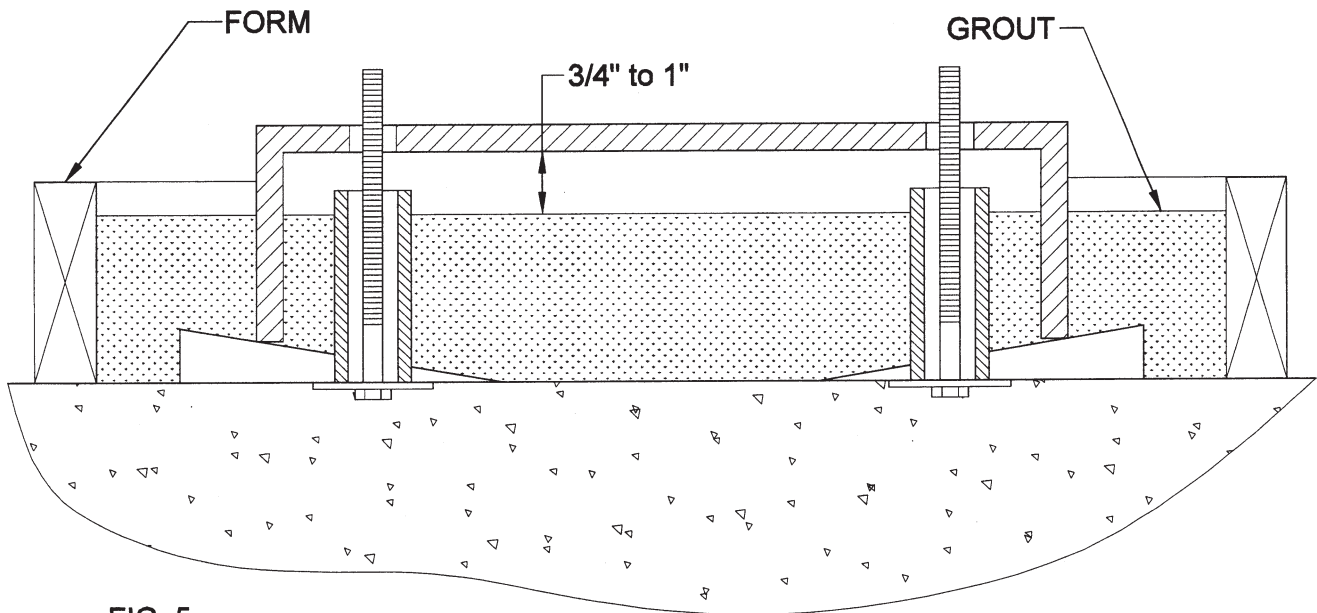

FIG. 5

PIPING

Guidelines for piping are given in the "Hydraulic Institute Standards" available from the Hydraulic Institute, 30200 Detroit Road, Cleveland, OH 44145-1967 and must be reviewed before installing pump.

! WARNING !

Never force piping into position by pulling it in place with the pump suction and discharge flange bolts. This will cause misalignment between pump and driver which will adversely effect the operation of the unit resulting in physical injury and damage to the equipment.

1. All piping must be supported independently of the pump.

2. Before connecting the piping to the pump, ensure that grout has hardened and the foundation bolts have been tightened.
3. When handling liquids at high temperatures, it is recommended that expansion loops or joints be properly installed in suction and/or discharge lines so that linear expansion of piping will not draw pump out of alignment.
4. On pumps handling corrosive liquids, the piping should be arranged to allow for flushing prior to removal.
5. Clean all pipe parts prior to installation.
4. When using a strainer on the suction, install it as close to the pump as possible and select a strainer with a net area of at least four times that of the suction pipe.
5. Whenever possible the end of the suction should be a minimum of 3' below the liquid level (Fig 6). The liquid near the pump suction should be free from agitation to prevent air entering the suction line.
6. Liquid coming back into the reservoir should not enter near the pump suction pipe, and the liquid should not drop from a high level (Fig. 6).
7. If a foot valve is not used in the suction line, it is good practice to bell out the suction pipe to lower the entrance velocities at the inlet (Fig. 6).

! WARNING !

$NPSH_A$ must always exceed $NPSH_R$ as shown on Gusher performance curves. Reference Hydraulic Institute for $NPSH$ and pipe friction values needed to evaluate suction piping.

Properly installed suction piping is necessary for trouble-free pump operation. Flush suction piping before connection to the pump.

1. Never place a pipe line elbow in the horizontal plane directly at the pump suction. Use a straight pipe four to six pipe diameters long between the elbow and the pump suction.
2. Use suction pipe one or two sizes larger than the pump suction, with an eccentric reducer, sloping side down, at the suction flange (Fig. 7). Suction piping should never be smaller than the pump suction.
3. Never throttle pump on the suction side, always control flow by throttling on the discharge side of the pump.

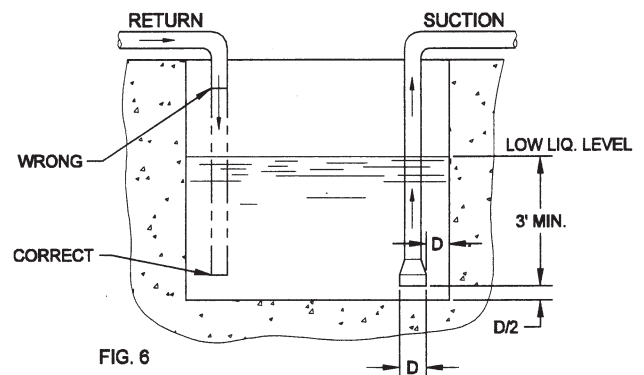

Suction Lift Conditions

1. Pipe must be free from air pockets.
2. Pipe must slope upwards to pump.
3. All connections must be air tight.

4. Whenever possible avoid dynamic suction lifts of more than 15'.
5. A means of priming the pump must be provided.

Suction Head/Suction Conditions

1. An isolation valve should be installed in the suction pipe at least four diameters from the suction to allow closing of the line for pump inspection and maintenance.
2. Pipe must be free from air pockets.
3. Piping should be level or slope gradually downward from the source.
4. No part of the piping should extend below pump suction flange.
5. The size of the entrance from the supply should be one or two sizes larger than the pipe.
6. To prevent vortices and air entrainment at the supply, the entrance from the supply must be adequately submerged below the liquid surface.

Discharge Piping

1. A gate valve and check valve should be installed in the discharge line. The check valve should be installed between the gate valve and the pump (Fig 7) this will allow for inspection of the check valve. The gate valve is required for priming, flow regulation, and for maintenance of the pump. The check valve

is required to prevent pump or seal damage from reverse flow through the pump when the motor is turned off.

2. Discharge pipe increasers should be connected between the pump and the check valve (Fig.7).
3. If quick closing valves are installed in the system, cushioning devices should also be installed to protect the pump from surges and water hammer.

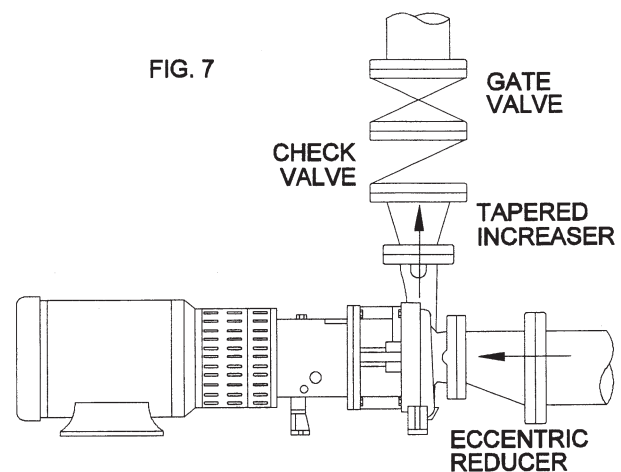

Final Piping Check

After all piping connections have been made to the pump:

1. Rotate the shaft by hand to ensure that there is no binding and all parts are free.
2. Recheck pump alignment to detect any pipe strain, if pipe strain exists correct piping.

OPERATION

PREPARATION FOR START-UP	15
CHECK ROTATION.....	15
CHECK IMPELLER CLEARANCE	15
COUPLE PUMP AND MOTOR.....	16
PRIME PUMP	16
INITIAL STARTING.....	17
OPERATION	17
FINAL ALIGNMENT	17

PREPARATION FOR START-UP

Check Rotation

1. Wire motor according to motor manufacturer's specifications and according to state and local regulations.
2. Lock out power to driver
3. Disconnect motor/pump shaft coupling to prevent dry operation of the pump and reverse rotation.

! WARNING !

Operating pump dry will cause damage to mechanical seal and may cause rotating parts to seize.

4. Make sure everyone is clear. Jog motor starter, pump must rotate clockwise when viewing from the driving end looking over the motor. Direction arrows are cast in impeller housings.

Check Impeller Clearance

Before starting pump the impeller clearance must be checked. The pump efficiency is maintained when the proper impeller clearance is

set. When pumping liquids under 200°F (93°C), the impeller front clearance for the S, M, and L is between .010" and .015". If the impeller front clearance is not set between the above values significant performance degradation will result. When pumping liquids above 200°F (93°C) the front impeller clearance when cold must be set per Table 2. This is necessary to allow for differential expansion due to the higher operating temperature. See the Maintenance section for correct impeller adjustment procedure.

TABLE 2 IMPELLER CLEARANCES	
Cold Temperature Clearances For Various Service Temperatures	
Service Temperature	Clearance
Up to 200°F (93°C)	.010" - .015"
200°F to 250°F (121°C)	.012" - .017"
250°F to 300°F (149°C)	.014" - .019"
300°F to 350°F (177°C)	.016" - .021"
350°F to 400°F (204°C)	.018" - .023"
Over 400°F (204°C)	.020" - .025"

Couple Pump and Motor

1. Lock out power to motor to prevent accidental rotation and physical injury.
2. Install and lubricate coupling per manufacturer's instructions.
3. Install coupling guard (see Appendix 3 Coupling Guard Installation instructions).

! WARNING !

Never operate a pump without the coupling guard properly installed. Personal injury can occur if pump is run without coupling guard.

Prime Pump

No centrifugal pump will operate satisfactorily until it has been properly primed. Do not attempt to prime pump when operating and DO NOT under any circumstances operate the pump without being completely primed. Some of the most common methods of priming are flooded suction, foot valve in suction line, ejector (steam, water, or air operated), and vacuum pump.

With flooded suction:

1. Slowly open the gate valve in the suction line.
2. Remove the air vent in the top of the pump casing to release entrained air.
3. Close the air vent once liquid starts to flow out of it.

With foot valve in suction line:

1. Open air vent on pump casing.
2. The pump and suction line must be filled with the liquid being pumped. It is recommended

to fill the discharge pipe several feet above the pump discharge.

3. After filling pipe and pump close air vent.
4. The pump will remain primed unless the foot valve leaks or if the liquid is contaminated and does not allow foot valve to close tight.

With an ejector:

1. Mount ejector at the highest point in the impeller housing to ensure removal of all the air in the casing and suction pipe.
2. Operate ejector with gate valve in discharge line closed.
3. Operate until ejector discharges a full steady flow of liquid.
4. On pumps using packing it may be necessary to tighten packing gland to prevent pulling of air through shaft clearances. After pump is primed properly loosen gland to achieve a slight trickle of liquid through stuffing box.

With a vacuum pump:

1. Mount vacuum pump at the highest point in the impeller housing to ensure removal of all the air in the casing and suction pipe.
2. Gate valve in discharge line must be closed.
3. After pump is primed, valves between vacuum pump and Gusher pump must be closed.
4. On pumps using packing it may be necessary to tighten packing gland to prevent pulling of air through shaft clearances. After pump is primed properly loosen gland to achieve a slight trickle of liquid through stuffing box.

INITIAL STARTING

1. The gate valve in the discharge line should be closed and gradually opened as the motor reaches full speed (approximately 5 to 10 seconds). After the pump has been in operation and the suction and discharge lines are filled with liquid, it is not necessary to close the gate valve when starting.
2. Start motor and immediately observe pressure gauges. If discharge pressure is not quickly attained stop pump, reprime, and attempt to restart.
3. If your pump is packed, loosen packing gland screws to allow free leakage. Then tighten screws uniformly on packing gland until leakage is reduced to approximately 30 drops per minute. Never tighten packing enough to stop all leakage, a slight leakage is required to lubricate packing and prevent scoring of shaft sleeve.
4. Check pump for vibration levels, bearing temperature, and excessive noise. If normal levels are exceeded, shut down and investigate.

OPERATION

Always vary the capacity with gate valve in the discharge line. Never restrict intake flow.

If the specific gravity of liquid being pumped is greater than originally assumed or if the rated flow is exceeded, the motor may overload.

To prevent damage from cavitation or recirculation, always operate pump at or near the rated conditions.

! WARNING !

DO NOT operate pump below minimum rated flows or with suction or discharge valves closed. These conditions could create an explosive hazard due to vaporization or pumpage and can quickly lead to pump failure and physical injury.

Drain all liquid from inside pump if it will be exposed to freezing conditions while idle. The conditions could cause liquid to freeze and damage the pump. Liquid inside cooling coils, if supplied, should also be drained.

FINAL ALIGNMENT

1. Run the unit under actual operating conditions long enough for the pump and motor to reach operating temperature.
2. Check alignment while unit is still hot.
3. Make any necessary adjustments and reinstall the coupling guards.

MAINTENANCE

BEARINGS	18
OIL LUBRICATED.....	18
GREASE LUBRICATED.....	18
COUPLING ALIGNMENT	19
SHAFT SEALS.....	19
PACKED PUMPS	19
MECHANICAL SEALS.....	20
SETTING IMPELLER CLEARANCE.....	21
TROUBLESHOOTING	22

BEARINGS

All pumps are lubricated at the Gusher plant and should not require additional lubrication for approximately 1200 hours of operation. A well planned maintenance schedule can only be devised after the first six months of operation and the lubrication record review at that time. Each pump installation is unique and requires individual attention to set up the proper lubrication schedule for each specific installation. About once every year it is recommended that the bearings be cleaned and flushed with carbon tetrachloride and then relubricated.

Oil Lubricated

A high quality turbine oil with rust and oxidation inhibitors, such as Mobil DTE 26 (300 SSU) or its equivalent, should be used. Fill bearing frame with oil until level is at the center of the sight glass.

TABLE 3 OIL CAPACITY	
Frame	Pints
S	.55 Approx.
M	1.25 Approx.
L	3 Approx.

Grease Lubricated

1. When regreasing ensure the grease container, greasing device, and the grease fittings are clean to prevent impurities from entering the bearing housing.
2. Remove the 2 grease relief plugs from the bottom of the bearing frame.
3. Fill both grease cavities with Chevron SRI #2 or equivalent until fresh grease comes out of relief holes.
4. Reinstall the grease relief plugs.
5. Check the frame seals to ensure they are seated in the bearing housing. If not, press into place with drains located at the bottom.

The bearing temperature will usually rise after regreasing due to an excess of grease. Temperatures should return to normal after the pump has purged the excess grease. Never mix greases of different consistency or thickener. If it is necessary to change, remove all of the old grease from the housing.

COUPLING ALIGNMENT

Coupling alignment must be checked before and after initial startup, after 300 hours of operation, and again after 1200 hours of operation. Follow procedures given in the Installation sec-

tion. Again, we strongly recommend setting up and following a routine maintenance program to ensure optimum life from your pump.

SHAFT SEALS

Packed Pumps

DO NOT STOP LEAKAGE! Packed glands drawn up too tight increases power consumption, increases wear on shaft, and shortens life of packing. When leakage can no longer be controlled by drawing up on the packing gland add another ring of packing to the stuffing box. After further operation and leakage again can no longer be controlled replace the packing by using the following procedure:

1. Remove all old packing from the stuffing box. Clean box and shaft sleeve thoroughly and examine for wear. Replace shaft sleeve if wear is excessive. Check bearing by lifting shaft up and down; do not expect packing to act as a bearing.
2. Use the right cross section of packing, Gusher uses Non-Asbestos packing as our standard for general purpose applications. Packing for special applications available, consult factory.
3. When using coil or spiral packing always cut the packing into separate rings. Never wind a coil of packing into a stuffing box. Rings can either be cut with butt (square) joint or diagonal joints. (Fig. 8) The best way to cut packing is on a mandrel the same diameter

as the shaft sleeve. Hold the coil packing tightly and firmly on the mandrel but do not stretch excessively. Cut the ring and try it in the stuffing box to make certain it fills the packing space properly with no gap in the joint at the O.D. of the ring. It is necessary that the rings be cut to the correct size, otherwise service life is reduced.

FIG. 8

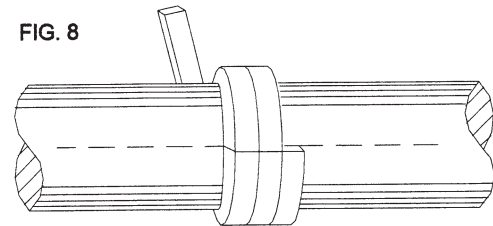

BUTT JOINT

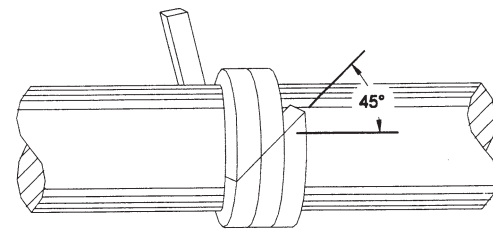

DIAGONAL JOINT

4. Install one ring at a time. Make sure it is clean and has not picked up any dirt in handling. If clean oil is available, lubricate the shaft and inside of the stuffing box. Seat rings firmly. (Except for TFE filament and graphite

yarn packings which should be snugged up very gently. Then wrench in gradually.. .after the pump is back in operation.) Joints of successive rings should be staggered and kept at least 90° apart. Each individual ring should be firmly seated with a tamping tool. When enough rings have been individually seated so the nose of the gland will reach them, individual tamping should be supplemented by the gland. Never depend entirely on the gland to seat a set of rings properly- this practice will jam the last rings installed, but leave the bottom rings loose in the box.

5. After the last ring is installed, take up bolts finger tight or very slightly snugged up. Do not jam the packing into place by excessive gland loading. Start pump, and take up bolts until leakage is decreased to a minimum. Make sure gland bolts are taken up evenly, stopping leakage entirely at this point will cause packing to burn up.
6. Allow packing to leak freely when starting up a newly packed pump. Excessive leakage during the first hour of operation will result in a better packing job over a longer period of time. Final adjustment should allow approximately 30 drops per minute to leak from the packing.
7. When specified, Gusher can provide means of lubricating the shaft and packing through a lantern ring by supplying water, oil, grease, or liquid handled in the pump.
8. If the stuffing box has a lantern ring, make sure the lantern ring, as installed, is slightly behind the fluid inlet as gland pressure is applied. (Fig 9)

FIG. 9

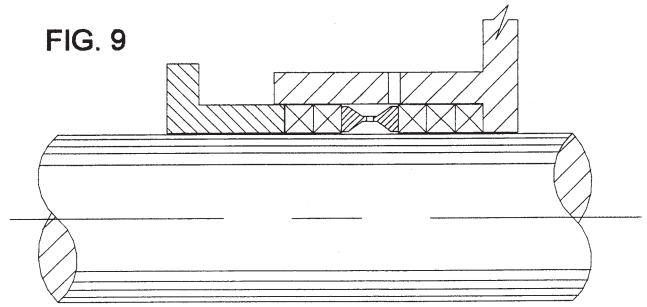

9. Replace packing when leakage cannot be controlled by further take up on the gland.

Some of the most common reasons for packing failure are:

- Improper installation
- Uneven gland adjustment
- Shaft misalignment and shaft whip
- Improper selection of packing for liquid
- Improper selection for pressure and temperature
- Contaminated liquid (dirt, abrasives, etc.)
- Operation without fluid

Mechanical Seal

The most important factor in the mechanical seal, other than the sealing qualities, is the fact that once it has been properly installed there is little or no maintenance required. Some of the most common reasons for seal failure are:

- Improper installation
- Shaft misalignment and shaft whip
- Wrong selection for liquid pumped
- Dirt or grit between faces
- Seal gland tightened unevenly so stationary seat is not perpendicular to shaft
- Operation without fluid

The life of a mechanical seal depends on various factors such as cleanliness and lubricating properties of liquid being pumped. Due to the diversity of operating conditions it is not possible to give definite indications to its life.

SETTING IMPELLER CLEARANCE

! WARNING !

Lock out motor power to prevent accidental startup and physical injury.

Over time a change in pump performance may be noticed. Performance can usually be renewed by resetting the impeller clearance.

Using a dial indicator (Fig. 10):

1. Remove coupling guards (see Appendix 3) and coupling.
2. Set the indicator so that the button on the dial is against the end of the shaft or the face of the coupling.
3. Loosen the jamb nuts and back out the adjusting screws about two turns.
4. Tighten the locking screws evenly until the front of the impeller bottoms on the impeller housing.
5. Tighten the adjusting screws by hand until they touch the bearing frame.
6. Set the indicator to zero and loosen locking screws about one turn.
7. Tighten the adjusting screws evenly, backing the impeller away from the housing until the indicator shows the required clearance.
8. Tighten the locking screws and jamb nuts evenly, being sure to maintain the proper clearance.
9. Check shaft for free turning, then reinstall coupling and guards.

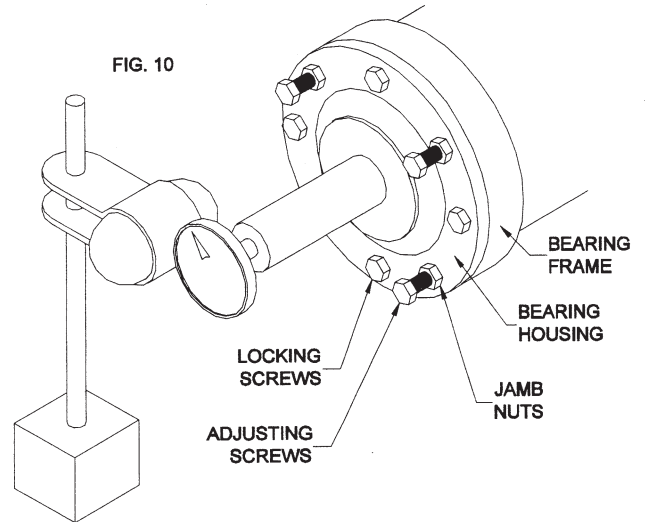

Using a feeler gauge:

1. Remove coupling guards (see Appendix 3) and coupling.
2. Loosen the jamb nuts and back out the adjusting screws about two turns.
3. Tighten the locking screws evenly until the front of the impeller bottoms on the impeller housing.
4. Using a feeler gauge, set the distance between the locking screws and the bearing housing to the required clearance.
5. Tighten the adjusting screws evenly until the bearing housing contacts the locking screws. Tighten the jamb nuts.
6. Check shaft for free turning, then reinstall coupling and guards.

TROUBLESHOOTING

No liquid delivered

- Pump not primed
- Speed too low*
- Discharge head too high
- Suction line or suction strainer is clogged
- Impeller completely clogged
- Wrong direction of rotation
- Too much clearance between impeller and intake flange.

Not enough water delivered

- Air leaks in suction or stuffing boxes
- Speed too low*
- Discharge head higher than anticipated
- Too much clearance between impeller and intake flange
- Impeller partially clogged
- Not enough suction head for hot water
- Mechanical defects:
 - Wear ring is worn
 - Impeller damaged
- Impeller diameter is too small
- Foot valve is too small
- Foot valve or suction opening not submerged deep enough.

Vibration

- Bent shaft
- Pipe strain
- Impeller clogged
- Coupling alignment off

Not enough pressure

- Speed too low*
- Air in water
- Mechanical defects:
 - Wear ring is worn
 - Impeller damaged
- Impeller diameter too small

Pump works for a while then loses suction

- Leaky suction line
- Water seal plugged
- Impeller clogged
- Air or gases in liquid

Pump takes too much power

- Speed too high*
- Head lower than rating, pumps too much water
- Specific gravity or viscosity too high
- Mechanical defects:
 - Shaft bent
 - Power frame in bind
 - Wear ring is worn
- Impeller diameter too large
- Pump delivering too many gallons

*When directly connected to electric motors, check for full voltage across all electrical leads.

DISASSEMBLY

TOOLS REQUIRED.....23
DISASSEMBLY23
INSPECTION25

TOOLS REQUIRED

- Spanner Wrench
- Shaft wrench
- 9/16", 3/4", 7/8", 15/16" Open End Wrenches
- 7/16" Open End Wrench (L Frame)
- Torque Wrench with sockets
- Allen Wrenches
- Snap-ring pliers
- Brass Drift Punch
- Lifting sling
- Feeler Gauge
- Dial Indicator
- Micrometer
- Induction Bearing Header
- Cleaning Agents

DISASSEMBLY

! WARNING !

Pump and components are heavy. Serious physical injury or damage to equipment could occur from failure to properly lift and support pump. Steel-toed shoes must be worn at all times.

! WARNING !

Operator must be aware of pumpage and safety precautions to prevent physical injury. Proper personal protective equipment should be worn.

! WARNING !

Lock out motor power to prevent accidental startup and physical injury.

1. Close suction and discharge valves.

2. Drain piping and impeller housing.
3. Remove coupling guards (see Appendix 3) and coupling sleeve.
4. On oil bath applications, drain oil from the bearing frame (13) and replace the drain plug.
5. Remove oil sight gauge (11).
6. Remove the cap screws that secure stem (18) to impeller housing (26).
7. Unbolt pedestal (14) from base.
8. Remove rotating assembly from impeller housing (26) using a hoist (Fig 11). Penetrating oil may be used if the joint is corroded. In many instances it is advisable to have a spare pump to install to keep down time to a minimum.

! WARNING !

NEVER use heat to disassemble pump. Explosion could occur due to trapped liquid.

! WARNING !

NEVER remove rotating assembly without assistance, physical injury can occur.

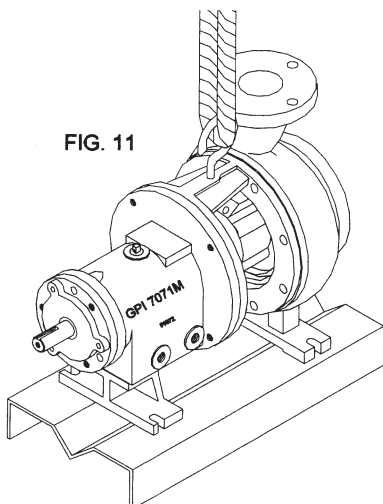

9. Remove stem plate gasket (24) and discard.

10. Mark location of coupling hub on the shaft, then remove.
11. Remove impeller (25) from the rotating assembly. To remove impeller, place shaft wrench on shaft and rotate impeller clockwise (viewed from impeller end of assembly) raising wrench off work surface. Quickly turn impeller opposite direction impacting wrench handle against solid block or work surface. Repeat process until impeller loosens. (Fig. 12)

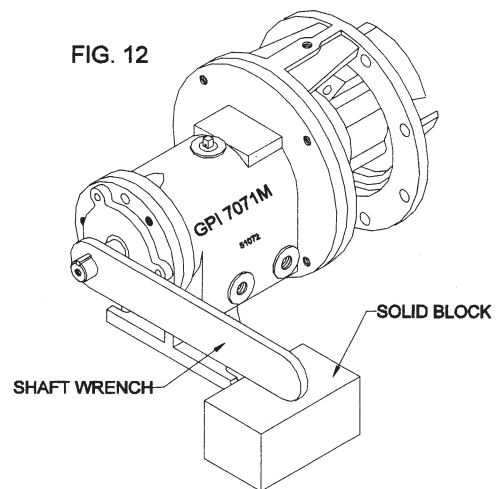

If impeller cannot be removed by the method described above, the shaft can be cut between the gland and the frame and the impeller and shaft end removed as a unit.

12. Remove the impeller o-ring (17) from the end of the impeller and discard.
13. Unbolt stem plate (23) from stem (18). Unbolt seal/packing gland (19) from stem plate. Remove the stem plate. On packed pumps, the packing and shaft sleeve (16) will usually come off with the stem plate.
14. Remove shaft sleeve (16) from shaft (9). Mechanical seal (21) will come off with sleeve. Remove mechanical seal and locking collar (22) from sleeve.

15. On packed pumps, remove packing and shaft sleeve (16) from either stem plate (23) or shaft (9).
16. Remove seal/packing gland (19) from shaft.
17. Unbolt and remove stem (18) from bearing frame (13).
18. Remove adjusting screws, jamb nuts, and locking screws from bearing housing (6).
19. Remove shaft and bearing housing assembly from bearing frame (Fig.13).

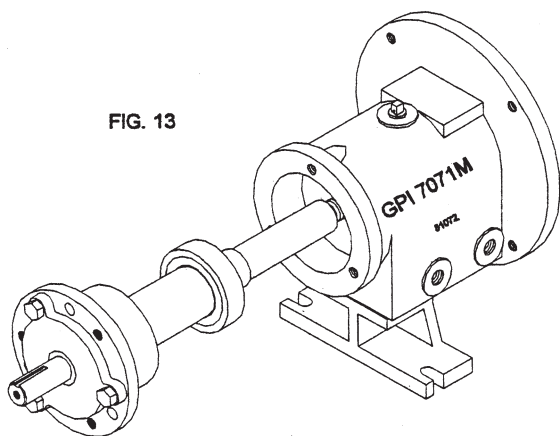

20. On S and M power frames remove oil seal (15) from bearing frame (13).
21. On L power frames remove radial bearing retainer (13b) from bearing frame (13). Remove oil seal (15) from radial bearing retainer.
22. Unbolt and remove thrust bearing retainer (2) from bearing housing (6). On S power frames this is one piece (2).
23. Remove oil seal (3) from thrust bearing retainer.
24. Remove snap ring (4) or lock nut (4) from shaft.
25. Slide bearing housing (6) off of thrust bearing (5).
26. Remove bearings (5 and 10) and bearing housing (6) from the shaft.
27. Remove bearing housing o-ring (7) from bearing housing.
28. Remove bearing frame breather (12) and pedestal (14) from bearing frame (13).

20. On S and M power frames remove oil seal (15) from bearing frame (13).

INSPECTION

After disassembly, the parts must be inspected to ensure that they will function properly after reassembly. Any parts that do not meet the following standards should be replaced.

1. Inspect the impeller housing (26) for excessive wear or pitting greater than 1/8" deep. Also inspect the stem plate gasket seat surface for irregularities.
2. Inspect the impeller (25) vanes for damage or wear. Replace impeller if vanes are grooved deeper than 1/16" or worn evenly more than 1/32". Inspect the edges of the vanes for pitting, erosion, or corrosion damage.
3. Inspect the stem (18) for cracks or excessive corrosion. Replace if any or these conditions exist. Ensure the gasket surface is clean.

4. Inspect the shaft (9) and sleeve (16) for grooves or pitting, replace if any are found. Ensure the shaft bearing fits are within the tolerances in Table 4. Also, check that shaft runout does not exceed the values in Table 5.
5. Inspect the bearing frame (13) and pedestal (14) for cracks. Remove all loose foreign material from inside the frame. Ensure that all lubrication passages are clear.
6. Inspect stem plate (23) for pitting or wear greater than 1/8" deep, and make sure that the gasket surface is clean.
7. Inspect the bearing housing (6) for cracks and pitting. Check that the bore is within the tolerances. Replace bearing housing if bore exceeds these tolerances.
8. Inspect the bearings (5 & 10) for contamination or damage. If bearing damage is not from normal wear, correct the problem before using pump. Do not reuse bearings.

**TABLE 5
7071 SERIES SHAFT RUNOUT TOLERANCES**

	SLEEVE FIT	COUPLING FIT
WITH SLEEVE	.002	.001
WITHOUT SLEEVE	.001	.001

REASSEMBLY

REASSEMBLY	27
MECHANICAL SEAL.....	31
PACKING	31
ASSEMBLY TROUBLESHOOTING.....	32

TABLE 6			
7071 SERIES BOLT TORQUE			
LOCATION		LUBRICATED THREADS	DRY THREADS
IMPELLER HOUSING BOLTS	6" 7071S	30 FT-LBS	45 FT-LBS
	8" 7071S	20 FT-LBS	30 FT-LBS
	7071M	30 FT-LBS	45 FT-LBS
	7071L	30 FT-LBS	45 FT-LBS
BEARING FRAME TO STEM BOLTS		20 FT-LBS	30 FT-LBS
BEARING RETAINER	7071L	9 FT-LBS	12 FT-LBS

REASSEMBLY

S Power Frame

1. Install the oil sight gauge, bearing frame breather, pedestal, and oil drain plug in the bearing frame (13) and hand tighten.
6. Place new o-ring (7) onto bearing housing (2), and coat inside of bearing housing with oil.
2. Install the thrust bearing (5) on shaft #9, for bearing installation procedure see Appendix 4.
7. Coat outside of thrust bearing (5) with oil, and install bearing housing (2) on the shaft/bearing assembly. Then insert snap ring into groove inside of bearing housing. Locate the space between the ends of the snap ring in the oil return groove so as not to obstruct flow.
3. Thread locknut (4) onto shaft and tighten until snug.
4. Place the snap ring (6) over the shaft with the flat side facing the bearing.
5. Install the radial bearing (10) on the shaft. (see Appendix 4)

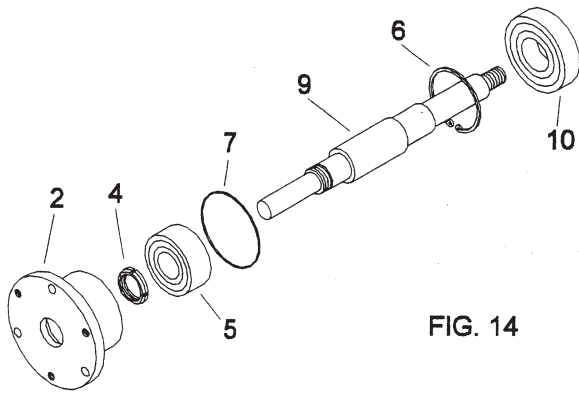

FIG. 14

8. Coat outside of bearing housing (2) and all internal surfaces of bearing frame (13) with oil.
9. Install shaft assembly into bearing frame. (Fig. 15)

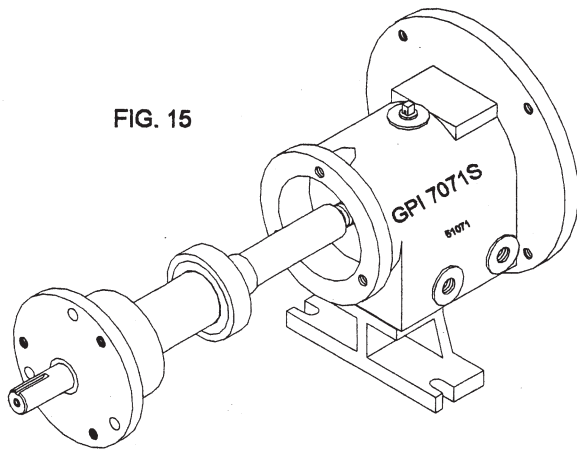

FIG. 15

10. Install locking screws and adjusting screws with jamb nuts, and hand tighten.
11. Install oil seal (1) in bearing housing.

M & L Power Frames

1. Install the oil sight gauge, bearing frame breather, and oil drain plug in the bearing frame (13) and hand tighten.
2. Install the thrust bearing (5) on shaft (9) for bearing installation procedure see Appendix 4.

3. Thread locknut (4) onto shaft and tighten until snug. On M power frame use snap ring (4).
4. Coat outside of thrust bearing (5) and the inside of bearing housing (6) with oil. Install bearing housing onto shaft/bearing assembly. Do not force assembly together.
5. Install thrust bearing retainer (2), gasket (3), and bolts. Torque bolts per Table 6 and check shaft for free turning.
6. Install radial bearing (10) onto shaft, for bearing installation procedure see Appendix 4.
7. Install new o-ring (7) onto bearing housing (6).
8. Install oil seal (1) into thrust bearing retainer (2).

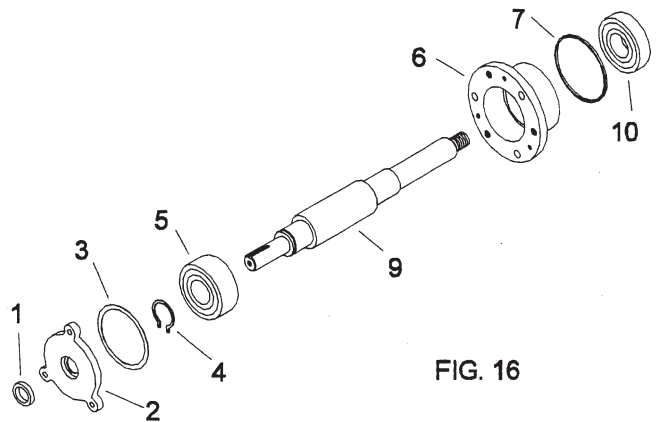

FIG. 16

9. Coat outside of bearing housing (2) and all internal surfaces of bearing frame (13) with oil.
10. Install shaft assembly into bearing frame (13).
11. Install locking screws and adjusting screws with jamb nuts, and hand tighten.

12. Attach pedestal (14) to bearing frame, hand tighten bolts.
13. On L power frame, install end plate gasket (13a), and end plate (13) on the bearing frame.

All Models

1. Support the power frame in a horizontal position.
2. Check shaft end play. Move the shaft forward and backward by hand, if total indicator reading is greater than the values in Table 7 disassemble the power frame and determine the cause. (Fig. 17)

TABLE 7	
SHAFT END PLAY	
7071S	.0011 / .0019
7071M	.0013 / .0021
7071L	.0014 / .0023

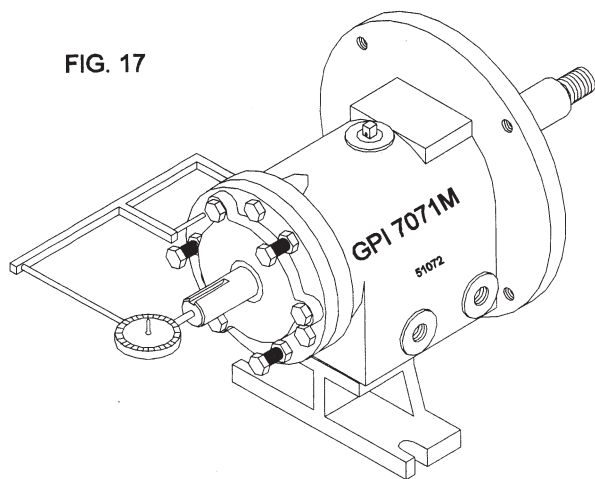

FIG. 17

3. Check shaft runout. Install shaft sleeve (16) and thread impeller (26) onto shaft. Hand tighten, then rotate impeller one turn. If reading varies more than .002 in. disassemble power frame and determine cause. Remove impeller and shaft sleeve. (Fig. 18)

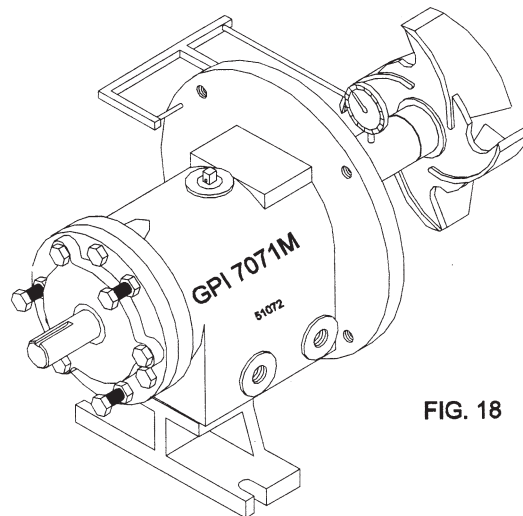

FIG. 18

4. Check bearing frame face runout. Rotate shaft as indicator rides along face of frame for one turn. If reading varies more than .001 in. disassemble frame and determine cause. (Fig. 19)

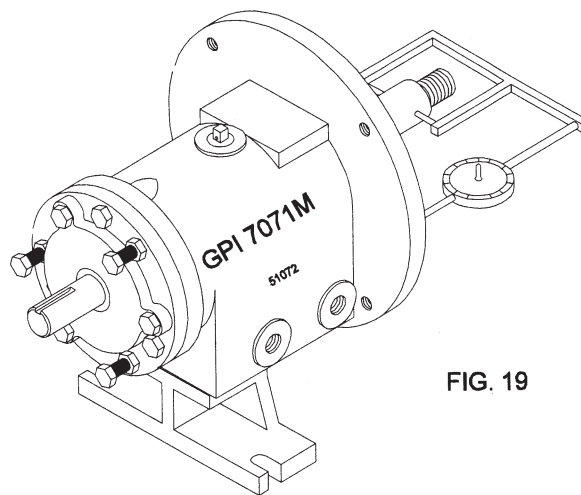
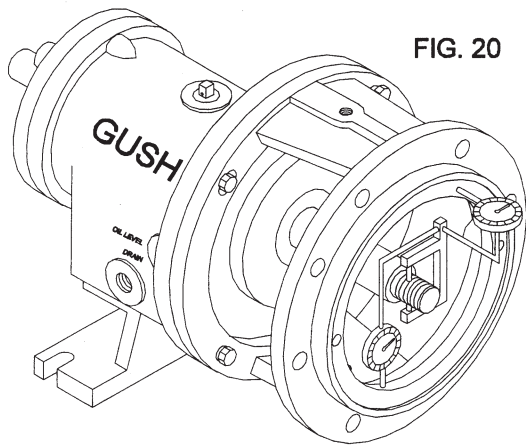
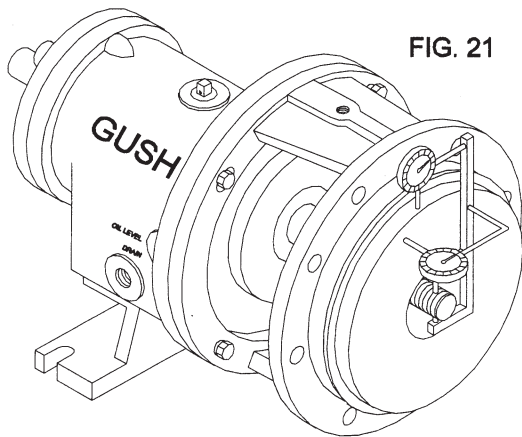

FIG. 19

5. Install stem (18) to bearing frame. Torque bolts, in a criss-cross pattern, to specifications in Table 6.
6. Check stem runout. Rotate shaft one turn, if reading varies more than .005 in. disassemble pump and determine cause. (Fig. 20)



7. Install oil seal (15) in bearing frame.
8. Install stem plate (23) to stem (18).
9. Check stem plate Rotate shaft one turn, if reading varies more than .005 in. determine cause and correct before continuing. (Fig. 21)



10. Install shaft sleeve (16) on shaft.
11. Thread impeller (25) with impeller o-ring (17) onto shaft.
12. Put shaft wrench on shaft and continue to thread impeller until it makes firm contact with sleeve.
13. Next, raise shaft wrench off work surface (counterclockwise if viewed from impeller end of pump), then slam it back down onto

work surface or a solid block. Repeat process a few times to tighten impeller. (Fig. 22)

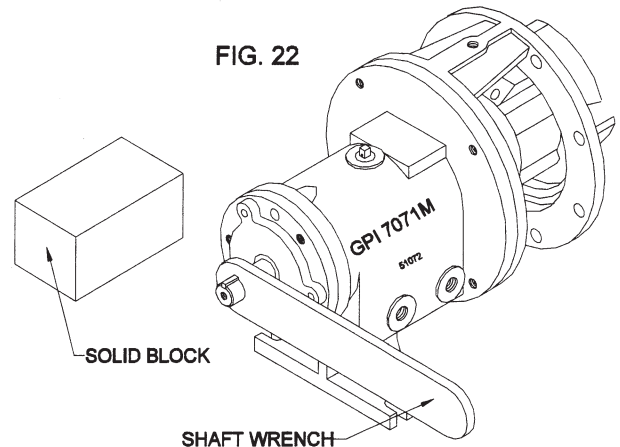

14. Loosen locking and jacking screws in bearing frame. Using a feeler gauge, adjust impeller until there is a .030 clearance between the impeller and stem plate. Tighten jacking and locking screws and jamb nuts.
15. Check impeller runout. If total reading, checked from vane tip to vane tip, varies more than .005 in. determine cause and correct before continuing. (Fig. 23)

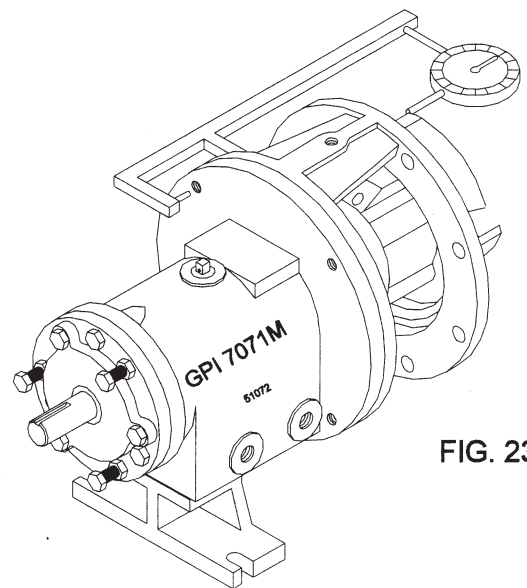

Mechanical Seals

1. Blue the shaft sleeve (16). Scribe a mark at the face of stem plate to use as reference for installation of mechanical seal. (Fig. 24)

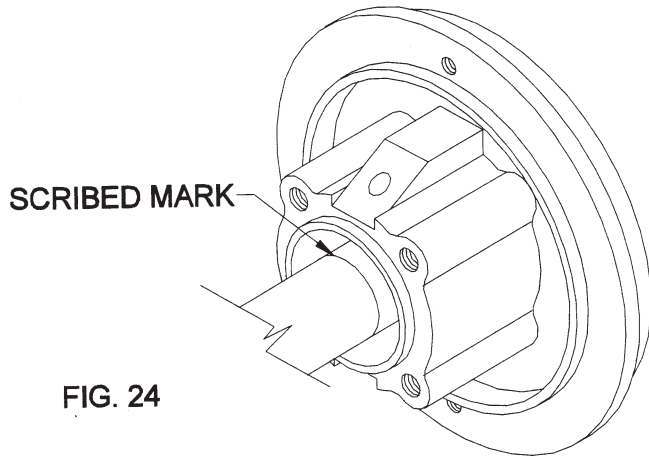

FIG. 24

2. Remove the impeller (25), shaft sleeve (16), and stem plate (23).
3. Install stationary seat of mechanical seal (21) into seal gland (19) per seal manufacturer's instructions.
4. Slide seal gland (19) with stationary seat and seal gland gasket (20) onto shaft.
5. Install mechanical seal (21) and locking collar (22) onto shaft sleeve per seal manufacturer's instructions.
6. Install shaft sleeve with mechanical seal onto shaft.
7. Then mount stem plate (23) to stem.
8. Reinstall impeller following same method previously used.
9. Mount seal gland (19) to stem plate.

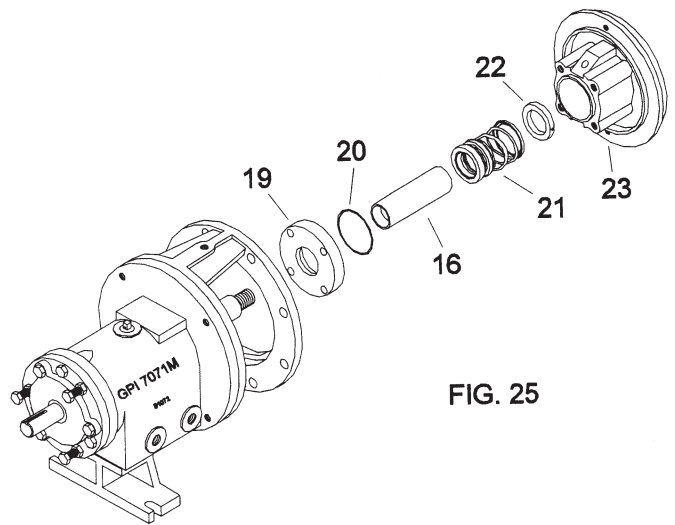

FIG. 25

Packed Pumps

1. Install packing and gland according to procedures in the Maintenance section of this manual.

All Models

! WARNING !

Pump and components are heavy. Serious physical injury or damage to equipment could occur from failure to properly lift and support pump. Steel-toed shoes must be worn at all times.

1. Clean fits between rotating assembly and impeller housing (26).
2. Place stem plate gasket (24) on stem.
3. Loosen locking and jacking screws in the bearing frame.
4. Install rotating assembly in impeller housing (26). Torque bolts according to values in Table 6. (Fig. 26)

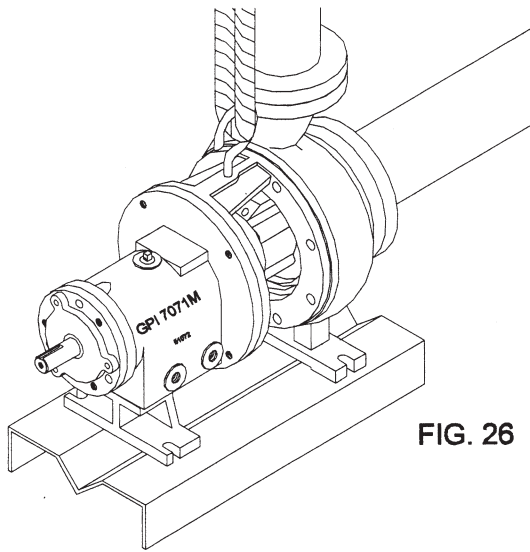

FIG. 26

5. Replace shims under frame feet and tighten frame to baseplate. A dial indicator should be mounted to measure the distance between the top of the frame and the baseplate. This measurement shouldn't change as bolts are tightened.

6. Check total travel of impeller in the casing, if it is more than .030 in. improper parts or installation or too much pipe strain is present. Determine cause and correct before proceeding.
7. Adjust impeller clearance using procedures in the Maintenance section of this manual.
8. Replace any auxiliary piping, and fill pump with proper lubricant as outlined in the Maintenance section of this manual.
9. Check to see that it is possible to rotate the shaft easily by hand, if so continue with startup of pump in Operation section of this manual. If shaft does not turn easily determine cause and correct.

ASSEMBLY TROUBLESHOOTING

Problem	Cause	Solution
Excessive shaft end play.	Bearing internal clearance too great.	Replace bearings with correct type.
	Snap ring loose in housing groove.	Reseat.
Excessive shaft runout.	Sleeve worn.	Replace.
	Shaft bent.	Replace.
Excessive bearing frame runout.	Shaft bent.	Replace.
	Bearing frame flange distorted.	Replace.
Excessive stem runout.	Corrosion.	Replace.
Excessive stem plate runout.	Stem plate not properly seated in stem.	Reseat.
	Corrosion or wear.	Replace.
Excessive impeller runout.	Bent vane(s).	Replace impeller.

APPENDIX

APPENDIX 1 - SPARE PARTS	33
APPENDIX 2 - DRAWINGS.....	35- 37
APPENDIX 3 - COUPLING GUARD INSTALLATION	38
APPENDIX 4 - BEARING INSTALLATION.....	39
APPENDIX 7 - RECOMMENDED MINIMUM FLOW.....	40

APPENDIX 1 - SPARE PARTS

If a spare pump cannot be justified, Gusher recommends several parts be kept in your stock for emergency situations. We recommend:

- Impeller (25)
- Shaft (9)
- Shaft Sleeve (16)
- Thrust Bearing (5)
- Radial Bearing (10)
- Stem Plate Gasket (24)
- Snap Ring (4)
- Locknut (4)
- Impeller O-Ring (17)
- Bearing Housing O-Ring (7)
- Oil Seal (Coupling End) (1)
- Oil Seal (Bearing Frame) (15)
- Mechanical Seal (21)
- Lantern Ring Half (Packed Pumps)
- Set of Packing (Packed Pumps)
- Packing Gland (Packed Pumps)

When ordering spare parts the following information should be provided to enable the factory to give precise and accurate information on part numbers for the pump in question:

- Serial Number
- Complete Model Number
- Discharge Size
- Part Description
- Horsepower and Current Characteristics
- Material of Construction
- Power Frame Size

APPENDIX 2 - DRAWINGS

PART NO.	DESCRIPTION	16	SHAFT SLEEVE
1	OIL SEAL (COUPLING END)	17	IMPELLER O-RING
2	BEARING HOUSING	18	STEM
4	LOCK NUT	19	SEAL GLAND
5	THRUST BEARING	20	SEAL GLAND GASKET
6	SNAP RING	21	SEAL 1 3/8 TYPE 21
7	BEARING HOUSING O-RING	22	LOCKING COLLAR
9	SHAFT	23	STEM PLATE
10	RADIAL BEARING	24	STEM PLATE GASKET
11	OIL SIGHT GAUGE	25	IMPELLER
12	BEARING FRAME BREATHER	26	IMPELLER HOUSING
13	BEARING FRAME		
14	PEDESTAL		
15	OIL SEAL (BEARING FRAME)		
15a	SLINGER		

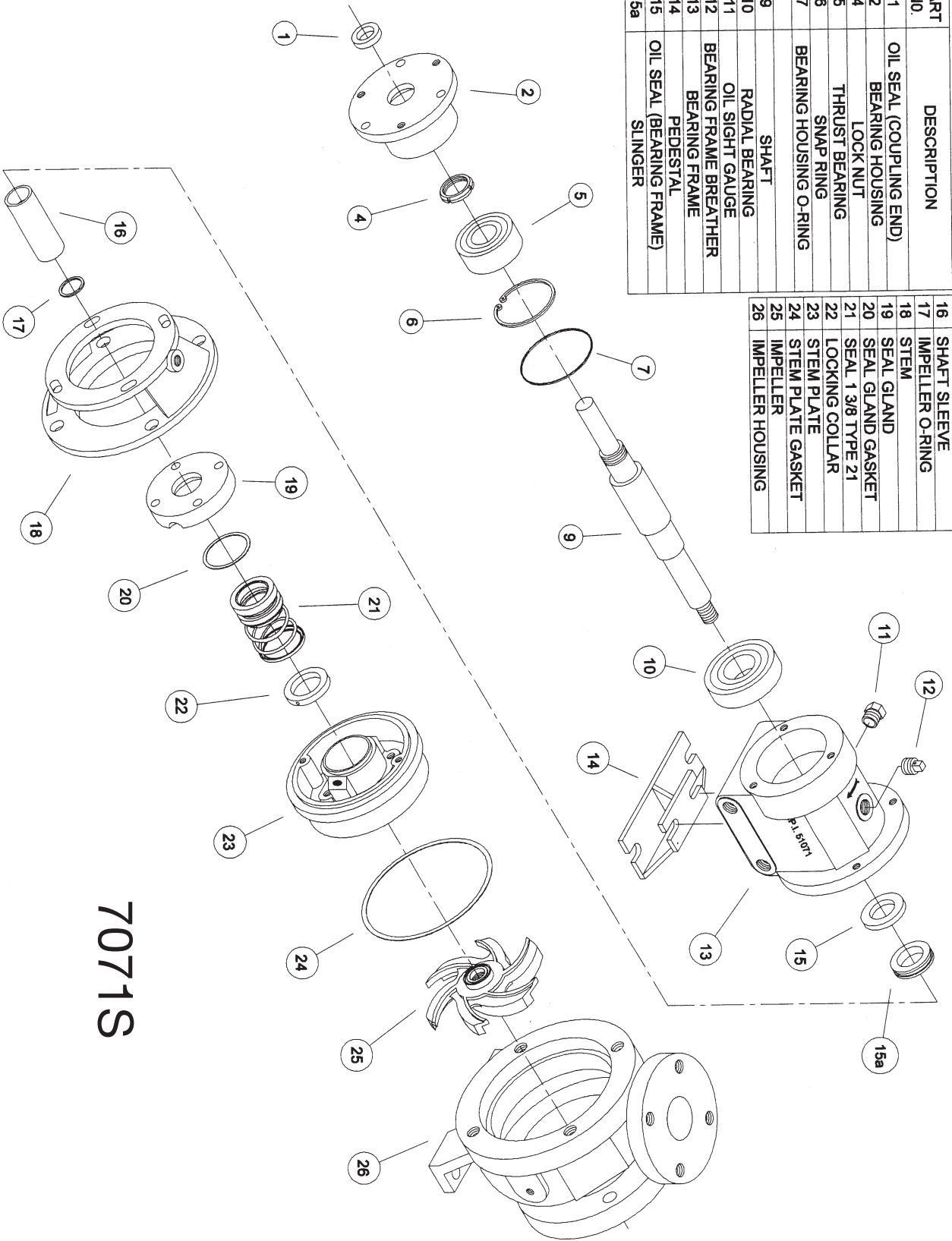

7071S

7071M

PART NO.	DESCRIPTION
1	OIL SEAL (COUPLING END)
2	THRUST BEARING RETAINER
3	THRUST BEARING RETAINER GASKET
4	SNAP RING
5	THRUST BEARING
6	BEARING HOUSING
7	BEARING HOUSING O-RING
8	DRIVE KEY
9	SHAFT
10	RADIAL BEARING
11	OIL SIGHT GAUGE
12	BEARING FRAME BREATHER
13	BEARING FRAME
14	PEDESTAL
15	OIL SEAL (BEARING FRAME)
16	SHAFT SLEEVE
17	IMPELLER O-RING
18	IMPELLER STEM
19	SEAL GLAND
20	SEAL GLAND GASKET
21	SEAL 1 3/4 TYPE 21
22	LOCKING COLLAR
23	STEM PLATE
24	STEM PLATE GASKET
25	IMPELLER
26	IMPELLER HOUSING

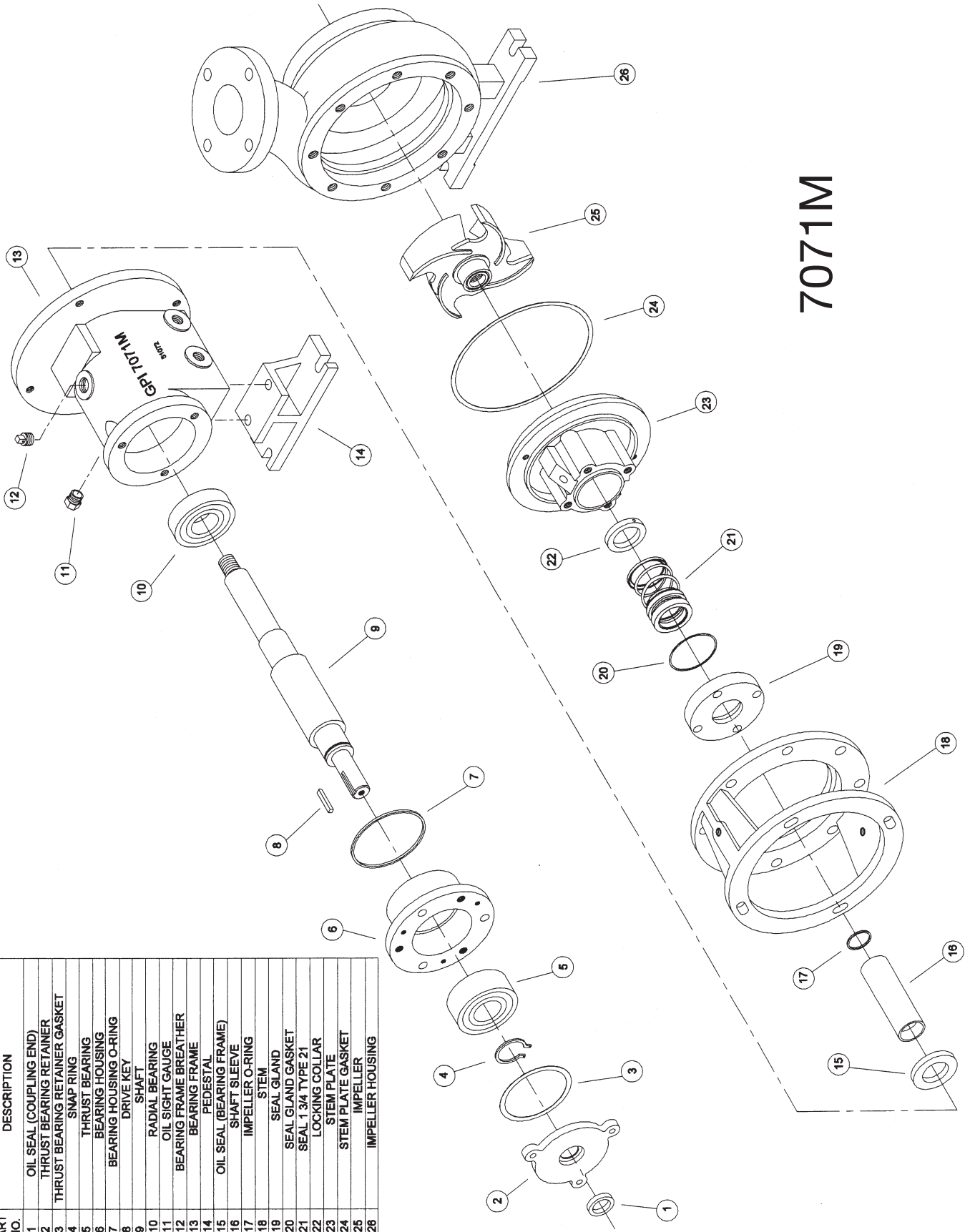

PART NO.	DESCRIPTION	PART NO.	DESCRIPTION
1	OIL SEAL (COUPLING END)	16	SHAFT SLEEVE
2	THRUST BEARING RETAINER	17	IMPELLER O-RING
3	THRUST BEARING RETAINER GASKET	18	STEM SEAL
4	LOCK NUT	19	SEAL GLAND
5	THRUST BEARING	20	SEAL GLAND GASKET
6	BEARING HOUSING	21	SEAL 2 1/2 TYPE 21
7	BEARING HOUSING O-RING	22	LOCKING COLLAR
9	SHAFT	23	STEM PLATE
10	RADIAL BEARING	24	STEM PLATE GASKET
11	OIL SIGHT GAUGE	25	IMPELLER
12	BEARING FRAME BREATHER	26	IMPELLER HOUSING
13	BEARING FRAME		
13a	END PLATE GASKET		
13b	END PLATE		
14	PEDESTAL		
15	OIL SEAL (END PLATE)		

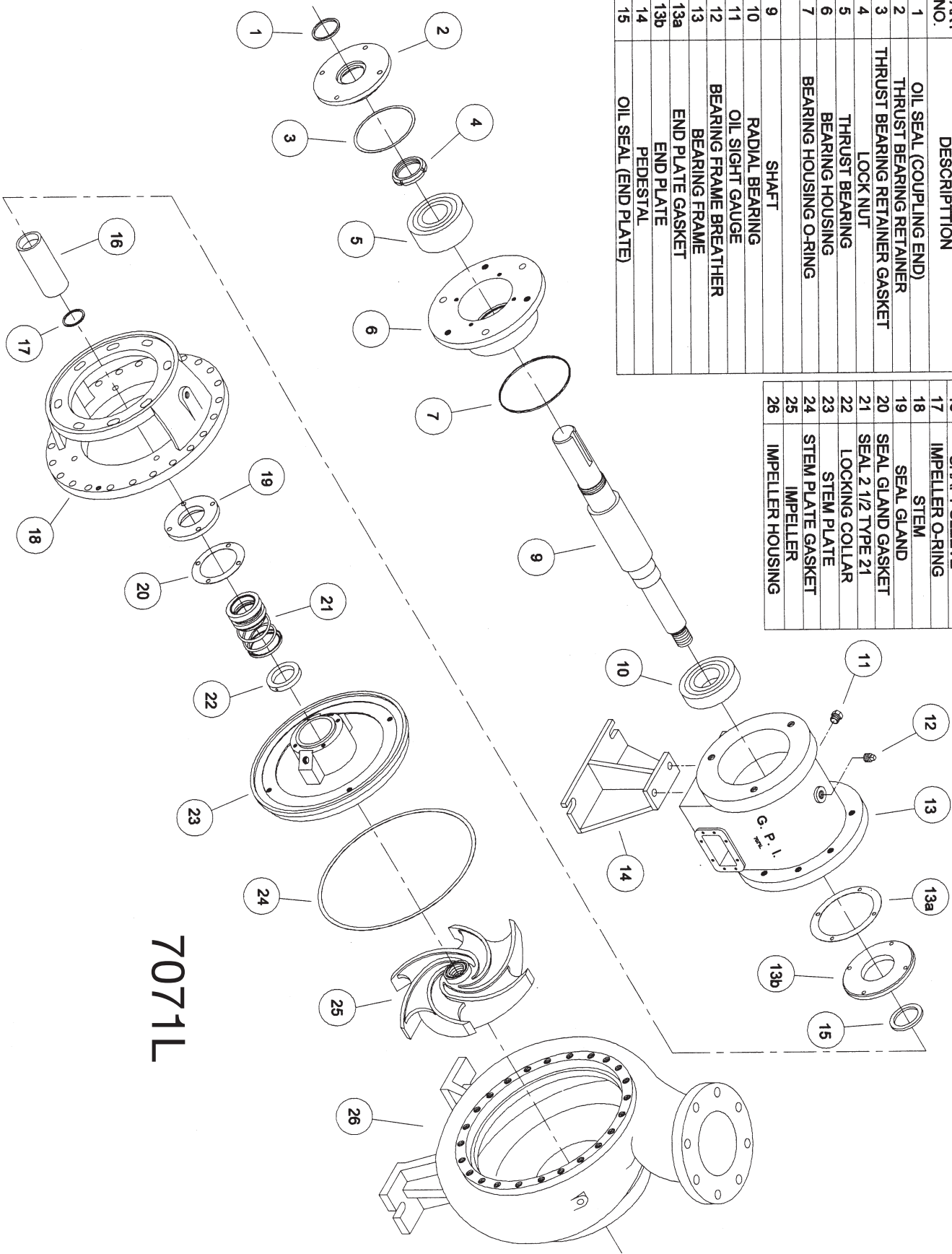

7071L

APPENDIX 3 - COUPLING GUARD INSTALLATION

! WARNING !

Before working with coupling guards, the motor must be de-energized, the motor controller/starter placed in a locked out position, and a caution tag placed at the starter indicating that service is being performed. Replace coupling guard before resuming normal operation of pump. Gusher Pumps, Inc. assumes no liability for avoiding this practice.

1. Attach the end plate to the rotating assembly and tighten the nuts. (Fig. 27)

FIG. 27

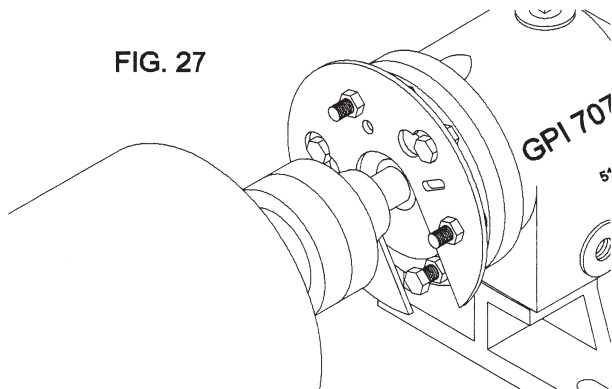

2. Spread bottom of coupling guard half and place it over the pump end plate. (Fig. 28) Locate the annular groove in guard half around end plate.

FIG. 28

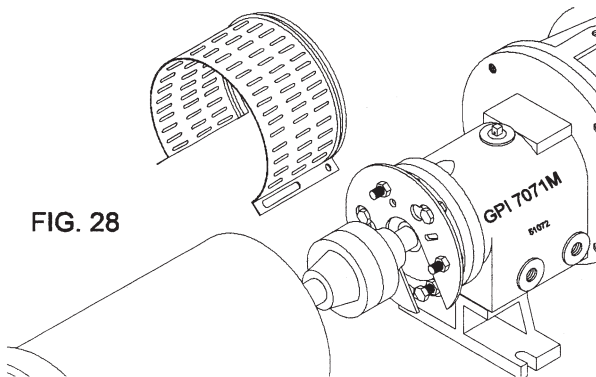

3. After coupling guard half has been positioned around the end plate, secure it with a bolt, nut, and two washers through the round hole in the front of the guard half.
4. Spread bottom of second coupling guard half and place it over the first half, ensure that the annular groove is faces the motor. (Fig. 29)

FIG. 29

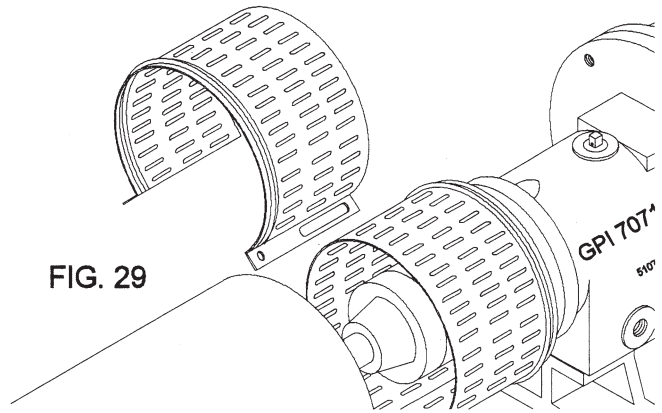

5. Place second end plate over the motor shaft and position it in the annular groove of the second guard half. Secure end plate using a bolt, nut, and two washers in the round hole.
6. Adjust the length of the coupling guard to completely cover the shafts and coupling by sliding the half on the driver end towards the motor. Once the desired length has been reached, secure it with a bolt, nut, and two washers through the slotted holes at the center of the guard.
7. Check all of the nuts on the guard assembly for tightness.

Note: The driver end plate does not attach directly to the motor.

APPENDIX 4 - BEARING INSTALLATION

1. Begin by cleaning your work area, contaminants can cause bearing failures as fast as any other reason.
2. The mounting force should be applied against the ring, and only the ring, which is being press-fitted. A bearing should never be forced onto a shaft by pressure or hammer blows applied to the outer ring, nor should the bearing be press-fitted into a housing by force applied to the inner ring.
3. Using an arbor press, the bearing may be laid on a face block which contacts only the bearing inner ring and which has a hole diameter greater than the bearing bore, as shown in Fig. A. The shaft is pressed through the bearing until it is seated firmly against the shaft shoulder.
4. If the shaft is not too long, it can be supported beneath the table of the arbor press and the bearing pressed onto it by ram pressure against a piece of soft metal tubing, as shown in Fig. B. The tubing must be clean,

inside and out, and the inside diameter of the tubing should be slightly greater than the bearing bore. The ends of the tubing should be square (with corners chamfered to avoid flaking) and should contact only the bearing inner ring. The shaft must be held in line with the ram of the arbor press to avoid cocking the bearing on the shaft seat.

5. When an arbor press is not available, the bearing can be driven onto the shaft seat by light hammer blows against the end of the soft metal tubing. These blows should be made alternately against opposite sides of the tubing face, and great care must be taken to avoid cocking the bearing as it is driven onto the shaft seat.
6. When a bearing is installed into a housing it is normally a slip fit, however if force is necessary to install bearing, the force should be exerted on the outer ring of the bearing as shown in Fig. C. Again the force must be applied evenly so as not to cock the bearing in the bore.

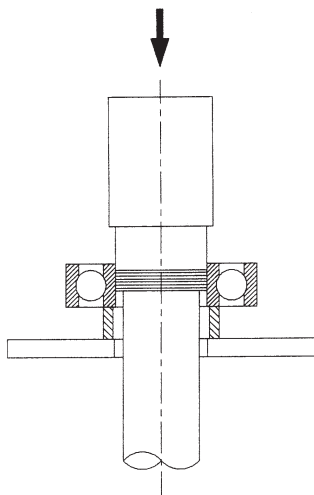

FIG. A

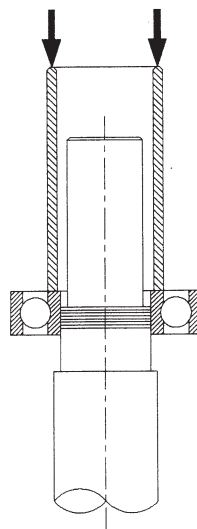

FIG. B

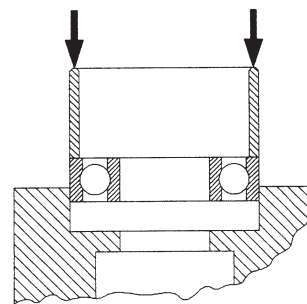
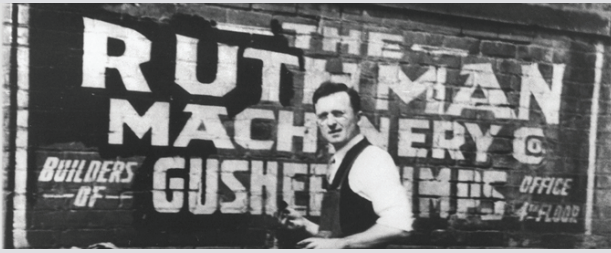

FIG. C

APPENDIX 7 – RECOMMENDED MINIMUM FLOW
7071 SERIES RECOMMENDED MINIMUM FLOW (GPM & MAXIMUM DIAMETER)

Pump Models	2 Pole 60 Hz	2 Pole 50 Hz	4 Pole 60 Hz	4 Pole 50 Hz	6 Pole 60 Hz	6 Pole 50 Hz	6 Pole 60 Hz
	3450 RPM	2850 RPM	1750 RPM	1450 RPM	1150 RPM	950 RPM	900 RPM
CL1X1.5-6SE	10	8	10	8	7	5	5
CL1.5X3-6SE	20	16	20	16	13	11	10
CL2X3-6SE	20	16	20	16	13	11	10
CL1X1.5-8SE	15	12	15	12	10	8	7
CL1.5X3-8SE	20	16	20	16	13	11	10
CL3X4-7SE			100	82	66	54	50
CL2X3-8SE	25	21	25	21	16	13	12
CL3X4-8SE	100	82	100	82	66	54	50
CL3X4-8BSE	75	62	75	62	49	40	37
CL5X6-9SE	150	123	150	123	98	80	75
CL1X2-10SE	20	16	20	16	13	11	10
CL1.5X3-10SE	20	16	20	16	13	11	10
CL2X3-10SE	50	41	50	41	33	27	25
CL3X4-10SE	50	41	50	41	33	27	25
CL3X4-10BSE	50	41	50	41	33	27	25
CL4X6-10SE			100	82	66	54	50
CL4X6-10BSE	150	123	150	123	98	80	75
CL4X5-11SE			150	123	98	80	75
CL6X8-11SE			150	123	98	80	75
CL1.5X3-13 SE	50	41	50	41	33	27	25
CL2X3-13SE	50	41	50	41	33	27	25
CL3X4-13SE	100	82	100	82	66	54	50
CL4X6-13SE			200	164	131	107	99
CL4X6-13SHC			200	164	131	107	99
CL6X8-13SE			400	328	262	214	199
CL6X8-13SHC			400	328	262	214	199
CL8X10-13SE			500	410	328	268	249
CL8X10-13SHC			500	410	328	268	249
CL6X8-15SE			400	328	262	214	199
CL8X10-15SE			500	410	328	268	249
CL8X10-15BSE			500	410	328	268	249
CL8X10-15SHC			500	410	328	268	249
CL3X4-16E			175	144	115	94	87
CL5X6-16E			200	164	131	107	99
CL4X6-17SE			300	246	197	161	149
CL6X8-17SE			400	328	262	214	199
CL8X10-17SE			500	410	328	268	249
V2X2-8SE			5	4	3	3	2
V2X2-10SE			20	16	13	11	10
V2X3-13SE			30	25	20	16	15
V3X3-10SE			30	25	20	16	15
V3X4-13SE			75	62	49	40	37
V4X6-13SE			130	107	85	70	65
V6X8-15SE			200	164	131	107	99

Ruthman Companies: A family-owned business supplying pumps for over 100 years



Ruthman Companies was co-founded in 1912 by brothers Alois and Edward Ruthman as the “Ruthman Machinery Company.” Based in Cincinnati, the company serviced the steamboats that traveled the Ohio River. In 1924, Alois conceived the first seal-less centrifugal pump, coining the term ‘coolant pump.’ The brothers named this new pump “Gusher,” giving birth to what is now Ruthman Companies’ flagship brand, Gusher Pumps.

Alois’ son Thomas R. Ruthman joined the family business in 1949, growing the business globally through organic growth and the acquisition of complementary technologies. In the early 1990’s, Alois’ grandson, Thomas G. Ruthman, became the third generation of Ruthmans in the pump business. Over the years, Ruthman Companies has expanded its product line from the original centrifugal coolant pumps to include valves, vertical turbine pumps, positive displacement pumps, gear pumps, and other specialized pump equipment, while upholding its reputation as a leader in the custom engineering of pumps for the most challenging applications.

GUSHER PUMPS LOCATIONS

Williamstown Headquarters

115 Industrial Road
Williamstown, KY 41097
Phone: 859.824.3011
Email: Info@Gusher.com
www.Gusher.com

Dry Ridge Manufacturing

22 Ruthman Drive
Dry Ridge, KY 41035
Phone: 859.824.5001
Email: Info@Gusher.com

Dry Ridge Training Facility

3565 Dixie Highway
Dry Ridge, KY 41035
Phone: 859.824.5001
Email: Info@Gusher.com

New Castle Sales & Service

403 North Ninth Street
New Castle, IN 47362
Phone: 765.529.5624
Email: GusherNC@Gusher.com

Gusher Pumps, Shanghai

655 Caosheng Road
Jiading District
Shanghai, China 201808
Phone: +86 (021) 55151993
Email: Flomo@Gusher.com

RUTHMAN COMPANIES MANUFACTURING DIVISIONS

BSM Pump Corp.

260 Narragansett Park Drive
East Providence, RI 02916
Phone: 401.471.6350
Email: Sales@BSMPump.com
www.BSMPump.com

Fulflo Hydraulic Valves

459 East Fancy Street
Blanchester, OH 45107
Phone: 937.783.2411
Email: Info@Fulflo.com
www.Fulflo.com

Nagle Pumps

3565 Dixie Highway
Dry Ridge, KY 41035
Phone: 859.428.5416
Email: Sales@NaglePumps.com
www.NaglePumps.com

Process Systems Inc. Headquarters

23601 Pinewood Street
Warren, MI 48091
Phone: 586.757.5711
Email: Sales@PSI4Pumps.com
www.PSI4Pumps.com

Process Systems Inc. Midwest Service

485 N. State Route 341 South
Mellott, IN 47958
Phone: 765.295.2206
Email: Sales@PSI4Pumps.com
www.PSI4Pumps.com

RAE Pumps

1212 Steng Street
Cincinnati, OH 45223
Phone: 513.779.3034
Email: Info@RAEPumps.com
www.RAEPumps.com

Ruthman Pumps & Service

1212 Steng Street
Cincinnati, OH 45223
Phone: 513.559.3546
www.RuthmanCompanies.com

Ruthmann Pumpen, LLC

Thomas-Edison-Str. 11
D-52499 Baesweiler
Germany
Phone: +49 (0) 2401 80489-0
Email: Info@RuthmannPumpen.de
www.RuthmannPumpen.de

RUTHMAN COMPANIES HEADQUARTERS

7236 Tylers Corner Drive
West Chester, OH 45069
Phone: 513.559.1901
www.RuthmanCompanies.com

