



A RUTHMAN COMPANY

# 7800 Series Vertical Pumps

11019-AVDSE

3450 RPM

Gusher 7800 Series Vertical pumps provide years of trouble-free, low maintenance operation. Heavy duty bearings require only periodic lubrication. Renewable shaft sleeves and bushings extend pump life.

A sealless design is standard, eliminating the most common point of pump failure—the mechanical seal. Instead, the internal components are specifically engineered to minimize leakage. Maintenance and downtime are significantly reduced as there are no failed or worn seals to replace.

The AVD model features a specially designed housing that discharges vertically. This results in a more compact footprint than adding a pipe elbow to a pump with side discharge construction.

The enclosed column design option offers the flexibility of external tank ('dry-pit') mounting. The outer column of the sealless pump contains any incidental fluid overflow and returns it to the process or discharge point. This design conserves costly process fluids and keeps shop floors dry and hazard-free.



## Key Specifications

**Type:** Centrifugal, End Suction

**Flow:** Up to 182 gpm

**Head:** Up to 170' TDH

**Liquid Temp:** Max 180° F

**Max Solid Size:** .375"

**Motor Type:** TCZ Frame

**Intake:** 2"

**Discharge:** 1.5"

**Power:** 1.5 hp, 2 hp, 3 hp, 5hp, 7.5 hp and 10 hp

## Features

- Sealless design reduces maintenance by eliminating the need for failure-prone seals
- Renewable shaft sleeve protects shaft from wear
- Design flexibility to suit your exact install specifications with extended lengths, multiple mounting plates and adjustable brackets

## Options

- Cast Iron or 316 Stainless construction
- Enclosed column
- Multiple bushing materials
- Impeller variations: 316 Stainless Steel or recessed design
- Long coupled design (CBM model pumps)
- Choice of 1 or 3 phase motor
- Extended shafts (6", 12", 18" or 24" standard; custom available, consult engineering)
- Adjustable mounting brackets
- Choice of plate shape/size



## Performance Curves

3450 RPM

### Recommended Operating Range

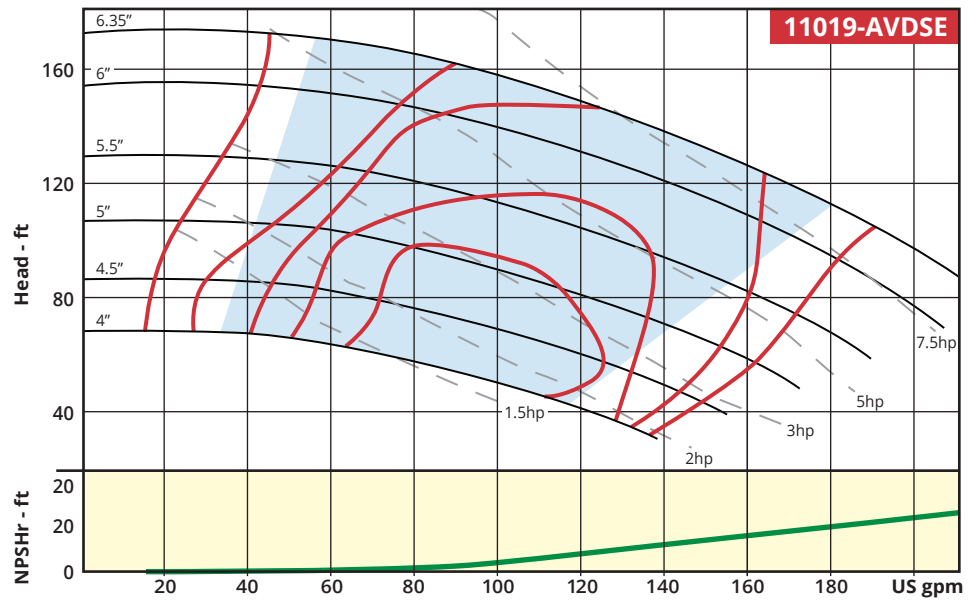

## Low Maintenance

- Long service life
- Renewable shaft sleeve and bushings

## Custom Design

- Choice of materials
- Enclosed column option
- Semi-enclosed impeller option

## Applications

- Cooling towers and chillers
- Wastewater
- Water purification
- Spray booths
- Parts washers
- Industrial washing machines

## Dimensions\*

HP	Total Length (A)	Below Bracket to Intake (B)	Weight (lbs)
1.5	27.125"	12"	126
2	27.125"	12"	131
3	27.875"	12"	156
5	29.25"	12"	176
7.5	30.50"	12"	186
10	31.00"	12"	236

For extended lengths (6", 12", 18", 24", or custom), add extension length to Total Length

\*For reference only; not for construction. Contact Gusher Engineering for certified drawings.

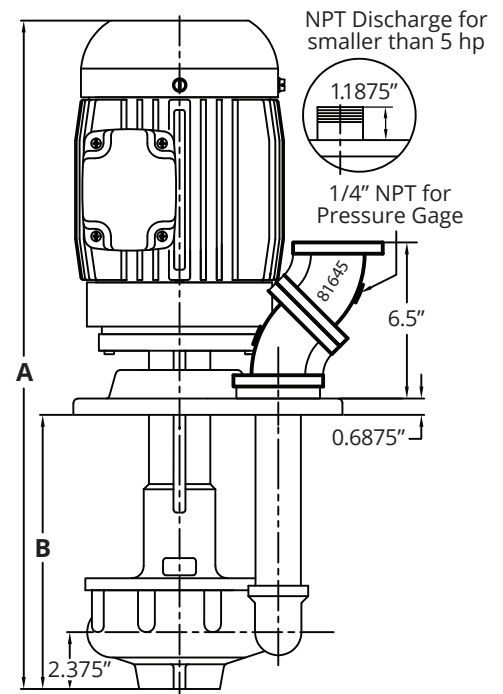
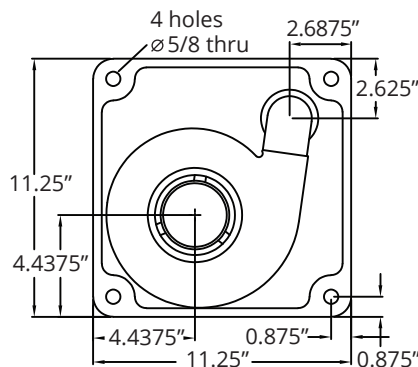

A RUTHMAN COMPANY

www.Gusher.com

Info@Gusher.com

859.824.5001