



A RUTHMAN COMPANY

# Vortex Series Vertical Pumps

VORTEX  
V3X4-13SE

1750 RPM

Gusher Vortex Series Vertical pumps provide years of trouble-free, low maintenance operation in applications with high levels of solids or entrained air.

Vortex pumps handle solids and fibrous materials without clogging. Their design moves liquids and oils containing up to 30% entrained air with no adverse effects on suction performance. Low flows are not a problem for Vortex pumps, as the design allows throttling to a low performance range unacceptable to many centrifugal pumps.

## Key Specifications

**Type:** Vortex Centrifugal End Suction

**Flow:** Up to 1,150 gpm

**Head:** Up to 210' TDH

**Liquid Temp:** Max 180° F

**Max Solid Size:** 3"

**Power Frame:** 52, 53 and 54VHD

**Motor Type:** TEFC, TC Frame

**Intake:** 4"

**Discharge:** 3"

**Power:** 30 hp, 40 hp, 50 hp, 60 hp, 75 hp and 100 hp



## Features

- Recessed impeller handles solids and fibrous material without clogging
- Durable CD4MCu impeller standard to prevent premature wear
- Choice of materials for process chemical compatibility
- Renewable shaft sleeves and bushings protect shaft from wear
- VFD compatible motors to suit application needs
- Power frame and spare wear parts interchangeable with Gusher 7550 Series pumps to streamline replacement part inventory

## Options

- Cast Iron, Ductile Iron, 316 Stainless Steel, CD4MCu construction
- Carbon or Tungsten Carbide bushings
- Extended lengths
- Flush line addition
- Top pullout design-on standard, +6 & +12 lengths only; subject to Gusher Engineering approval



## Performance Curve

1750 RPM

### Recommended Operating Range

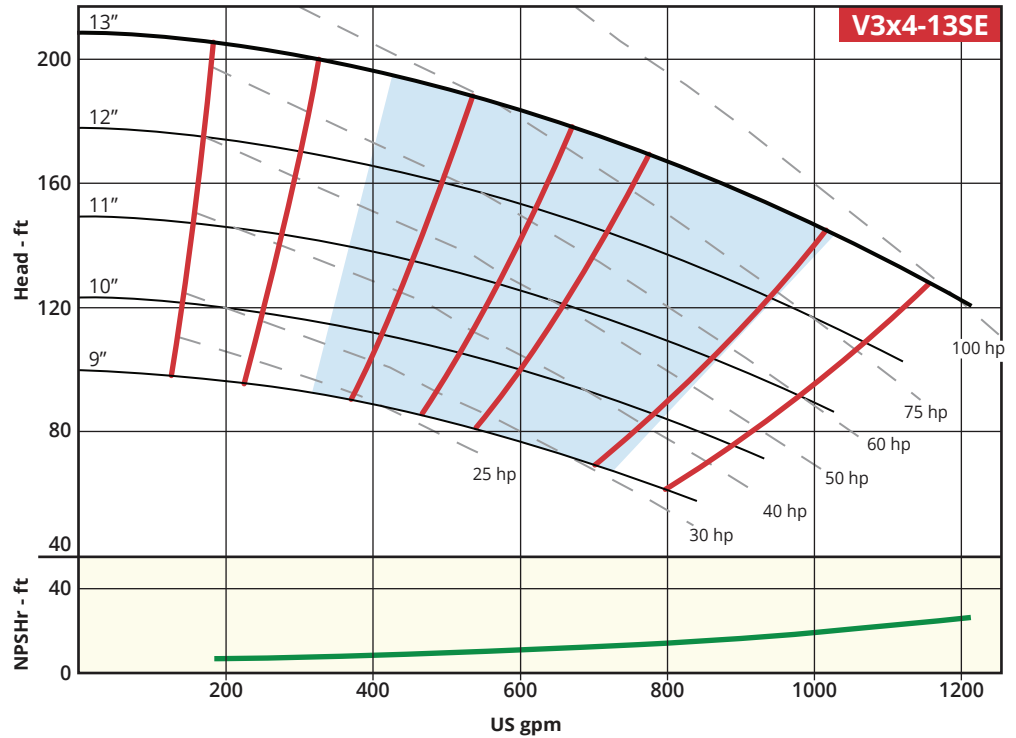

## Low Maintenance

- Long service life
- Top pullout design option
- Renewable shaft sleeve and bushings

## Custom Design

- Choice of materials
- Choice of pump length
- Choice of bushing material

## Applications

- Agriculture
- Fibrous Waste
- Sludge
- Shavings
- Swarf
- Paper Pulp
- Wastewater



A RUTHMAN COMPANY

www.Gusher.com  
Info@Gusher.com  
859.824.5001

## Dimensions\*

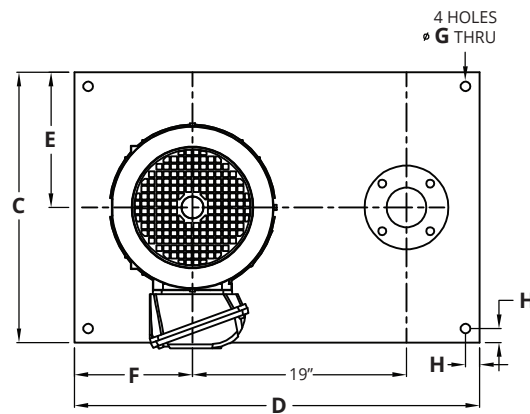

\*52 VHD drawing for reference;  
other power frames may vary slightly

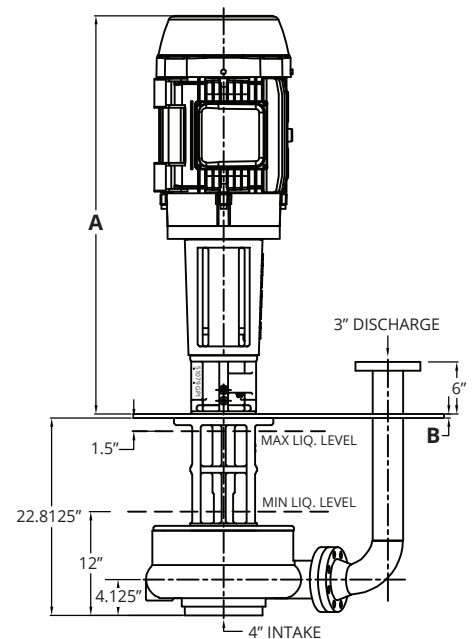

Power Frame	HP	NEMA Motor Frame Size	Above Plate Length (A)	Plate Thickness (B)	Plate Width (C)	Plate Length (D)	Plate Width Edge to Motor Center (E)	Plate Length Edge to Motor Center (F)	Hole Diameter (G)	MTG Hole Offset (H)	Weight (lbs)
52	30	286TC	43.50"	0.50"	24.00"	36.00"	12.00"	10.50"	0.875"	1.25"	1,065
	40	324TC	46.125"	0.50"	24.00"	36.00"	12.00"	10.50"	0.875"	1.25"	1,185
53	50	326TC	56.375"	1.00"	30.00"	42.00"	15.00"	14.00"	1.50"	2.00"	1,650
	60	364TC	59.50"	1.00"	30.00"	42.00"	15.00"	14.00"	1.50"	2.00"	1,920
54	75	365TC	57.875"	1.00"	32.00"	48.00"	16.00"	14.00"	1.50"	2.00"	2,000
	100	Contact Factory									

\*For reference only; not for construction. Contact Gusher Engineering for certified drawings.