



A RUTHMAN COMPANY

7071 Series ANSI Horizontal Pumps

PCL1.5x3-6SE
1750 RPM

Gusher 7071 Series ANSI Dimension Pumps provide years of trouble-free, low-maintenance operation. The series includes horizontal models in standard ANSI envelope sizes (B73.1), from AA to A120. To meet performance parameters for high flow, low pressure applications, the series includes models with ANSI construction in nonstandard sizes.

7071 Series pumps are built with a heavy-duty shaft and bearings. Problem-solving design features, such as external impeller adjustment and Back Pull-out construction eliminate maintenance hassles.

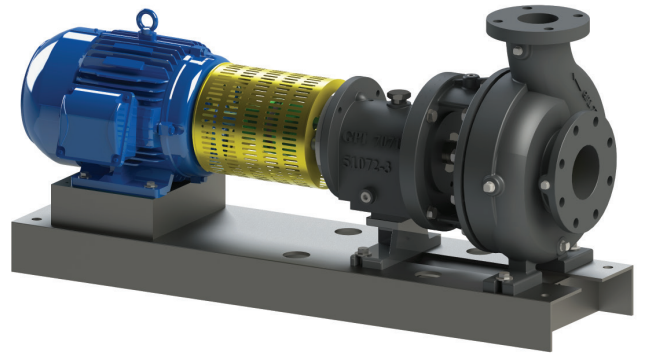

Key Specifications

Type: Centrifugal, End Suction

Flow: Up to 112 gpm

Head: Up to 37' TDH

Liquid Temp: Max 180° F

Max Solid Size: .44"

Intake: 3"

Discharge: 1.5"

Motor Type: TEFC, T Frame

Power Frame: 7071S

Impeller Type: Semi-enclosed

ANSI Size: AB

Features

- ANSI 73.1 style foot-mounted casing with ANSI 16.5 standard flanges for simple installation
- Series includes all ANSI envelope sizes, plus additional models to achieve higher flows at low pressures
- Centerline intake and discharge minimizes pipe stress and vibration
- Renewable shaft sleeve protects shaft from wear
- Back Pullout design speeds maintenance
- External impeller adjustment allows clearances to be set without downtime
- Gusher Quick Ship eligible for delivery of complete standard pumps in 4 weeks; parts in 2 or less

Options

- Ductile iron, 316 stainless steel, stainless fitted construction; other alloys available
- Packing or choice of multiple mechanical seal types and materials
- Standard bore and tapered bore seal chambers
- Cast iron base
- Single or Three Phase motor
- Seal flush line



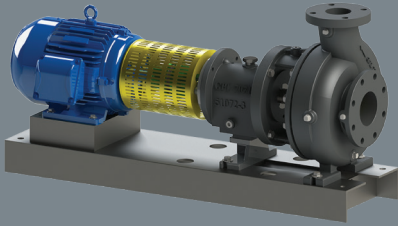

Performance Curves

1750 RPM

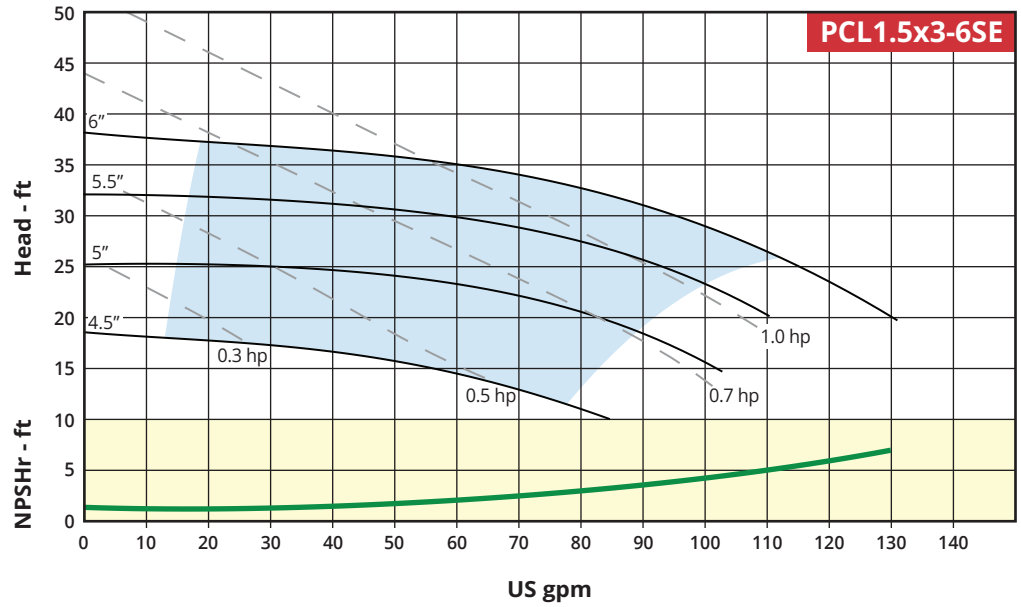

Low Maintenance

- Long service life
- Back pullout design
- Renewable shaft sleeve

Custom Design

- Choice of materials and seals
- Choice of seal chamber bore type
- Optional seal flush line

Applications

- Oil processes
- Municipal systems
- Filtration
- Wastewater
- Water purification
- Paint systems
- Paper pulp
- General industrial processes

Dimensions*

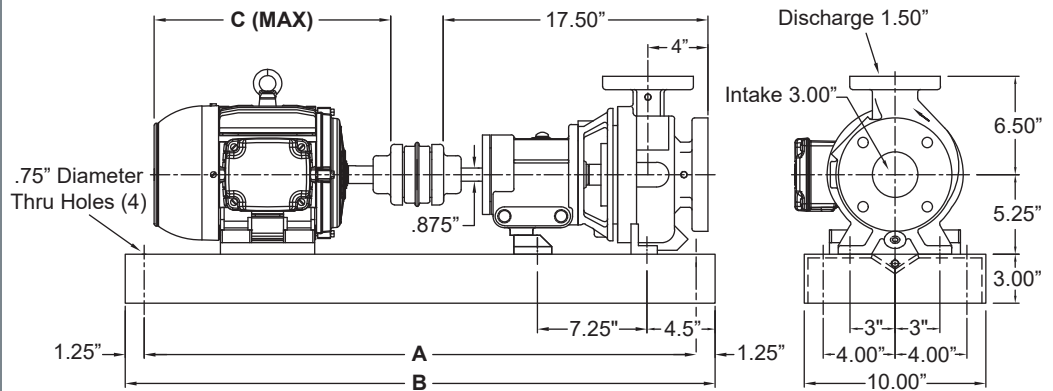

NEMA FRAME	BASE	A	B	C (MAX)
56-145	1S	32.50"	35.00"	13.50"

NEMA FRAME	BASE	MECHANICAL SEAL SIZE	BARE PUMP WEIGHT	BASE WEIGHT	MOTOR MAX. WEIGHT
56-145	1S	1.375"	95 lbs.	46 lbs.	50 lbs.

*For reference only; not for construction. Contact Gusher Engineering for certified drawings.



A RUTHMAN COMPANY

www.Gusher.com
Info@Gusher.com
859.824.5001